

Key to wiring diagram

1	Driving beam 55W (H3 halogen)
2	Tail light 5W
3	Dipped beam 55W(H1 halogen)
4	Front R.H. direction indicator, 10W
5	Front L.H. direction indicator, 10W
6	Dashboard
7	1-way AMP connector (RPM sensor, dashboard side)
8	PAKARD 10-way connector (dashboard)
9	Oil pressure switch
10	Neutral position switch
11	Fuel level switch
12	Horns
13	Horn relays (MINIRELAY SIEMENS)
14	PAKARD 10-way connector (L.H. device)
15	L.H. control device: lights, direction indicators, horn
16	Intermittence
17	Alternator 12 V330 W
18	Voltage regulator
19	Start relay (MINIRELAY SIEMENS)
20	Starter
21	Battery 12V 13Ah
22	Rear brake stop switch
23	L.H. rear direction indicator 10W
24	Rear stop light 21W
25	Rear tail light 5W
26	R.H. rear direction indicator 10W

27	Fuse box (see table)
28	Solenoid valves (electric taps)
29	Light relays (MINIRELAY SIEMENS)
30	5-way AMP connector
31	R.H. Device (Ignition - Run)
32	Front brake stop switch
33	4-way AMP connector
34	Key ignition switch
35	IAW 15M electronic unit
36	Air temperature sensor (NTC ATS05)
37	Three-way diagnosis AMP connector
38	Warning light LED
39	Cylinder ignition coil AT, LH (BAE850AK)
40	Cylinder ignition coil AT, RH (BAE850AK)
41	Power relay for injection (MINIRELAY SIEMENS)
42	Safety diode
43	ECU electronic unit relay (MINIRELAY SIEMENS)
44	Fuel pump
45	L.H. injector (IW031)
46	R.H. injector (IW031)
47	Phase sensor (SEN8I3)
48	Motor oil temperature sensor (NTC WTS05)
49	Throttle potentiometer (PF10)
50	Max. pressure sensor inside the electronic unit ECU
51	1-way AMP connector (key closed supply)
52	1-way AMP connector (RPM sensor, injection side)

Fuses

F1	Pump, coils, injectors 15A
F2	ECU electronic unit 15A
F3	Electric taps 15A
F4	Driving, dipping beam, horn, start, stop light 15A
F5	Tail lights 15A
F6	Direction indicators 15A

Key to cable colors

Arancio	=	Orange
Azzurro	=	Light blue
Bianco	=	White
Giallo	=	Yellow
Grigio	=	Grey
Marrone	=	Brown
Nero	=	Black
Rosa	=	Pink
Rosso	=	Red
Verde	=	Green
Viola	=	Violet
Bianco-Azzurro	=	White-Light blue
Bianco-Giallo	=	White-Yellow
Bianco-Marrone	=	White-Brown
Bianco-Nero	=	White-Black
Blu-Nero	=	Blue-Black
Giallo-Nero	=	Yellow-Black
Nero-Grigio	=	Black-Grey
Rosso-Bianco	=	Red-White
Rosso-Blu	=	Red-Blue
Rosso-Giallo	=	Red-Yellow
Rosso-Nero	=	Red-Black
Rosso-Verde	=	Red-Green
Verde-Grigio	=	Green-Grey
Verde-Nero	=	Green-Black
Rosa-Nero	=	Pink-Black

Marrone-Nero	=	Brown-Black
Bianco-Blu	=	White-Blue
Bianco-Verde	=	White-Green

26

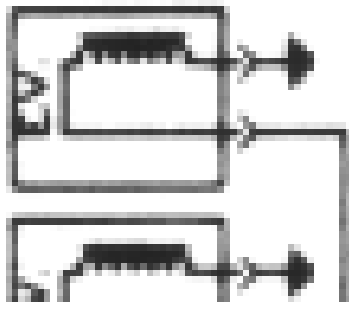

27

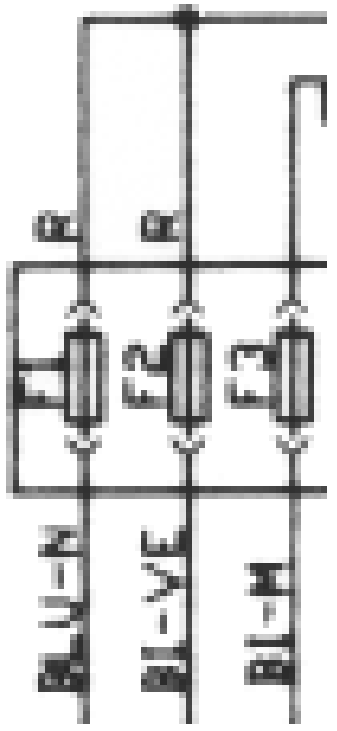

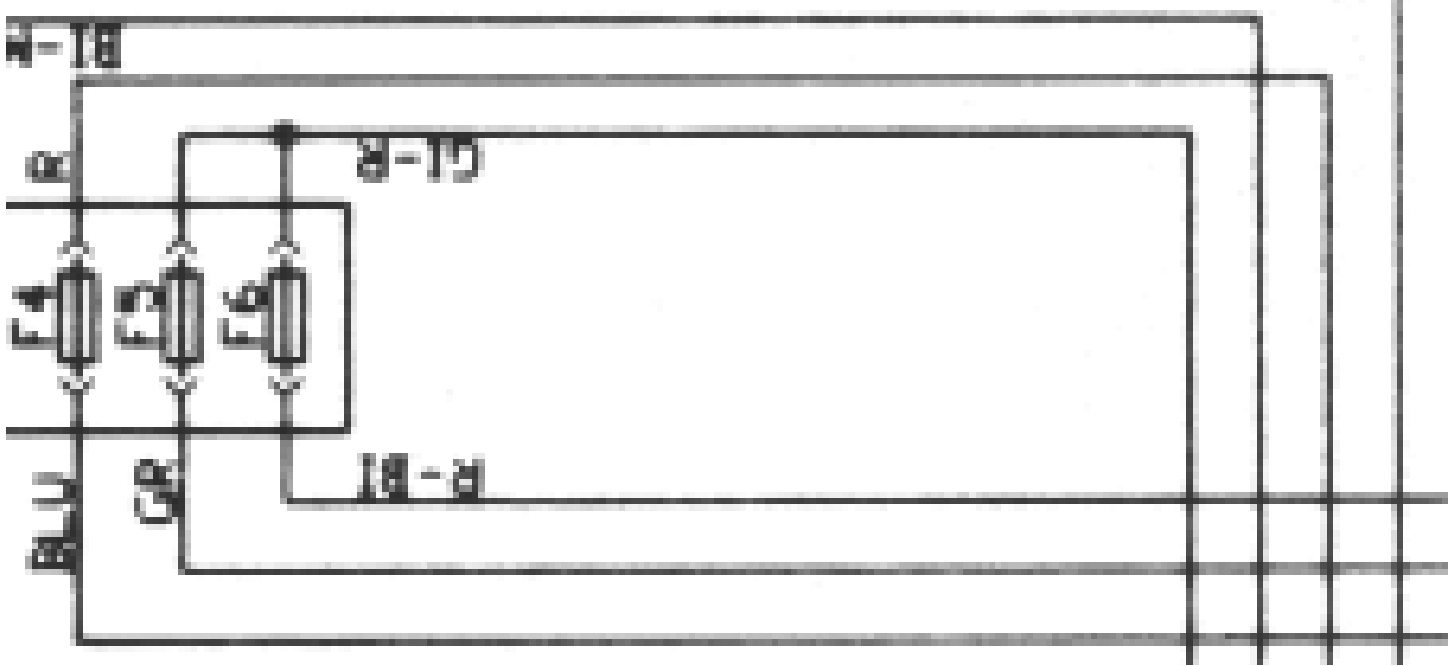

(26)

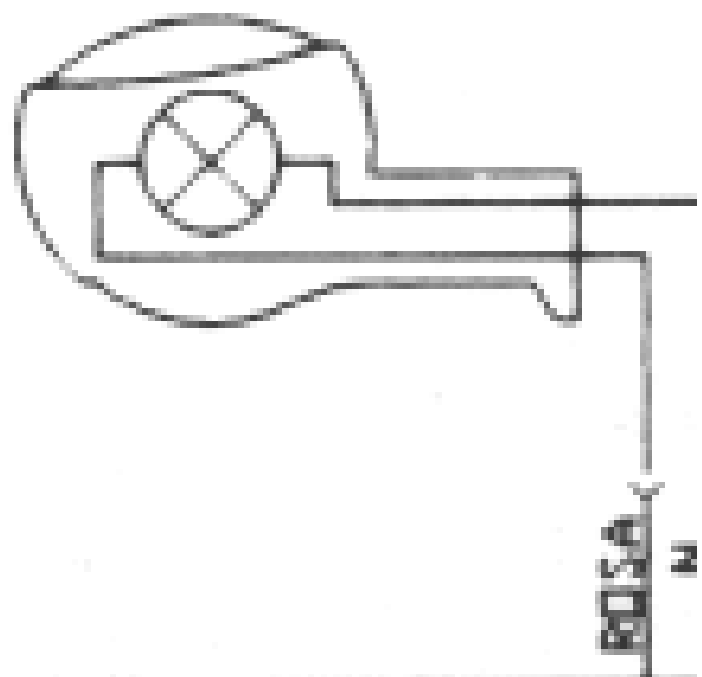

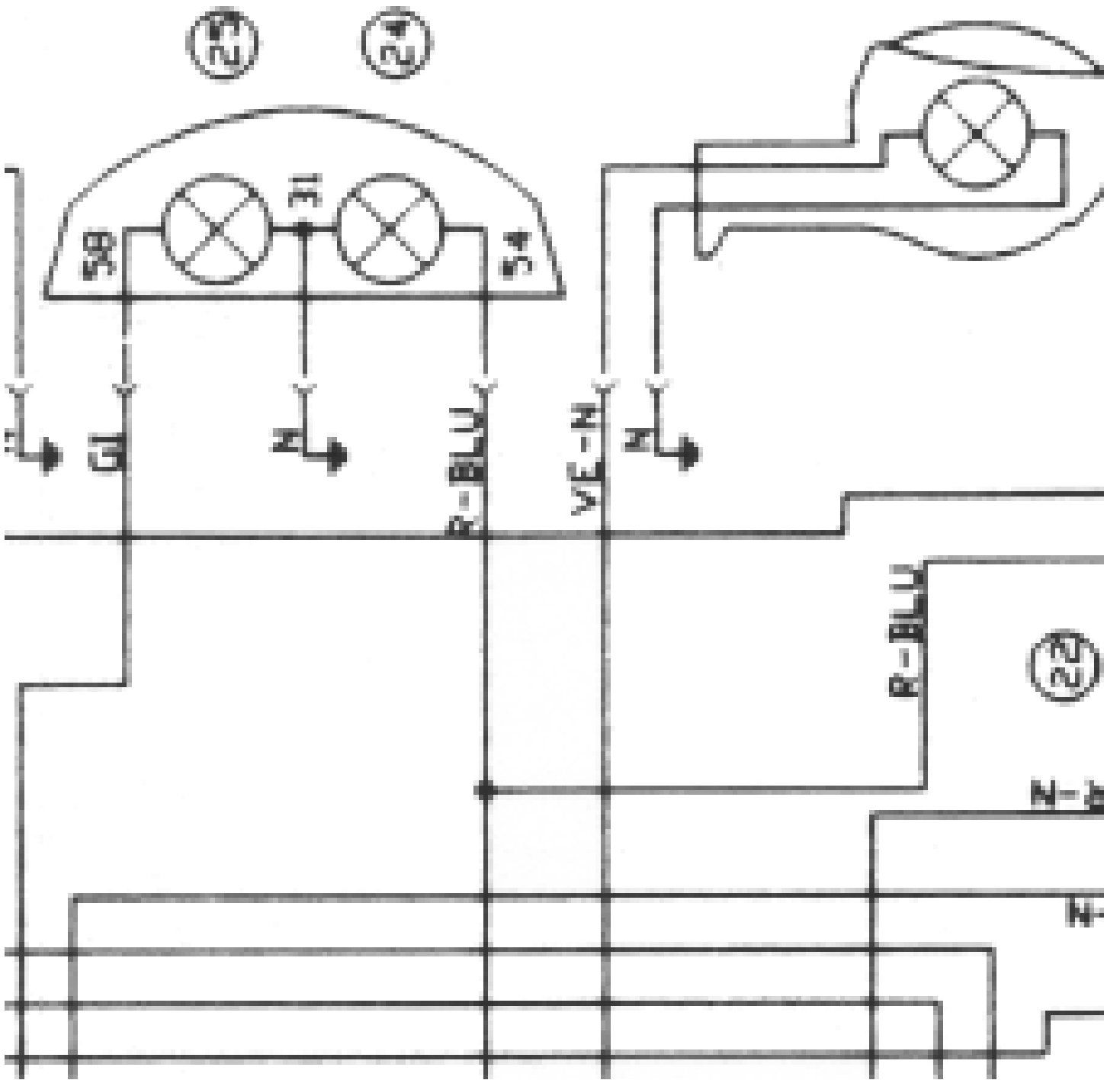

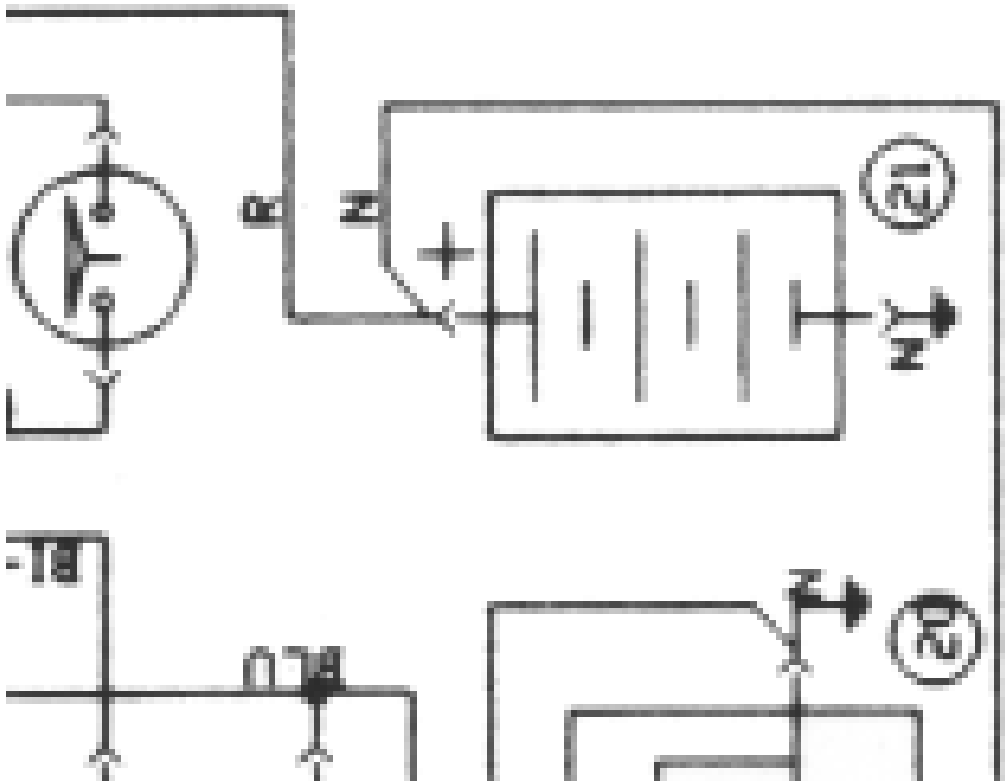

12

12

12

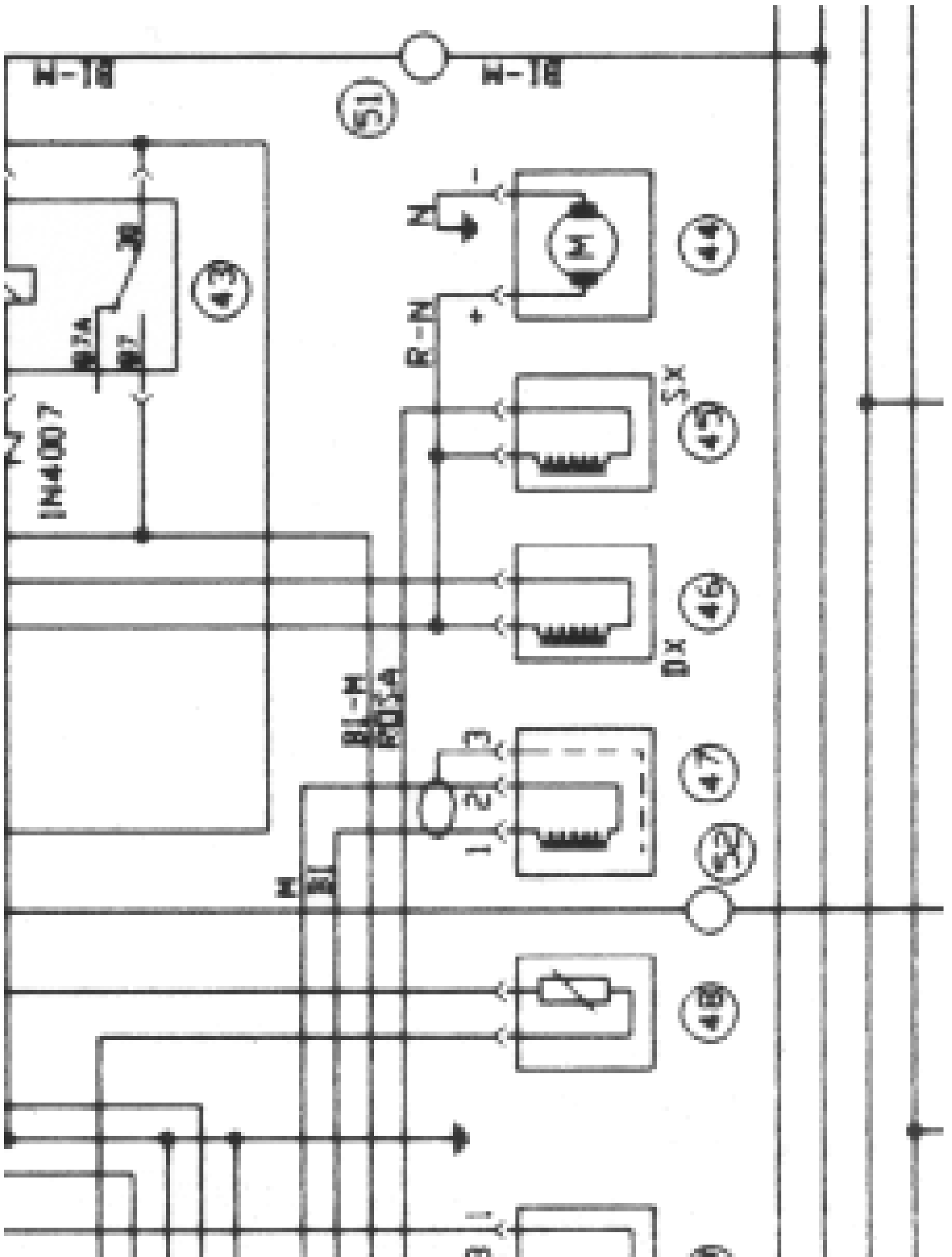

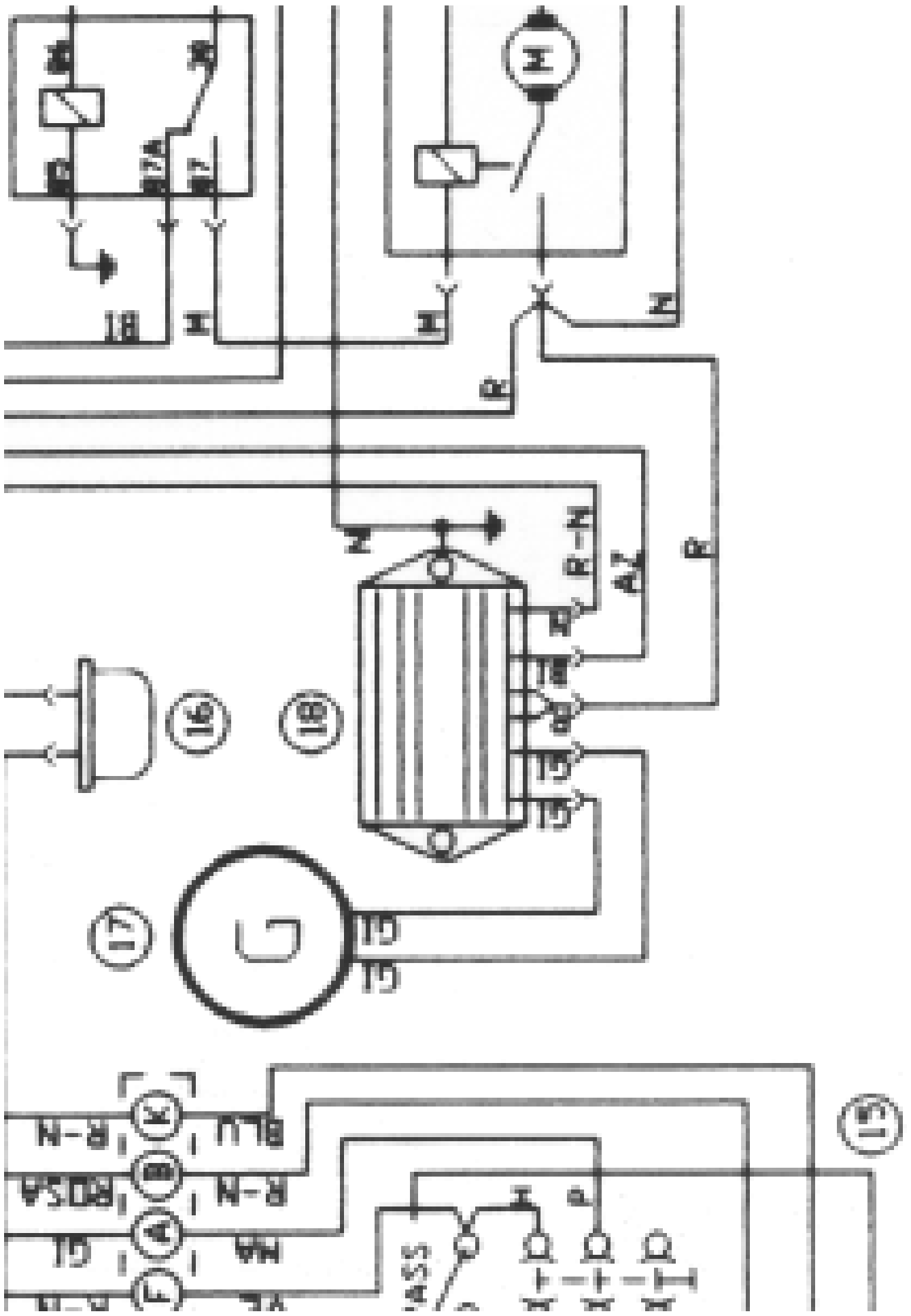

396

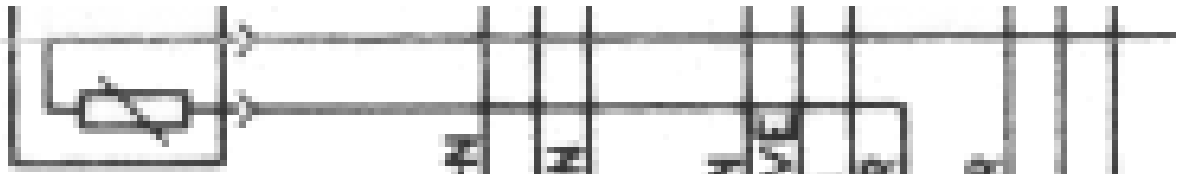

397



DC 15N



398

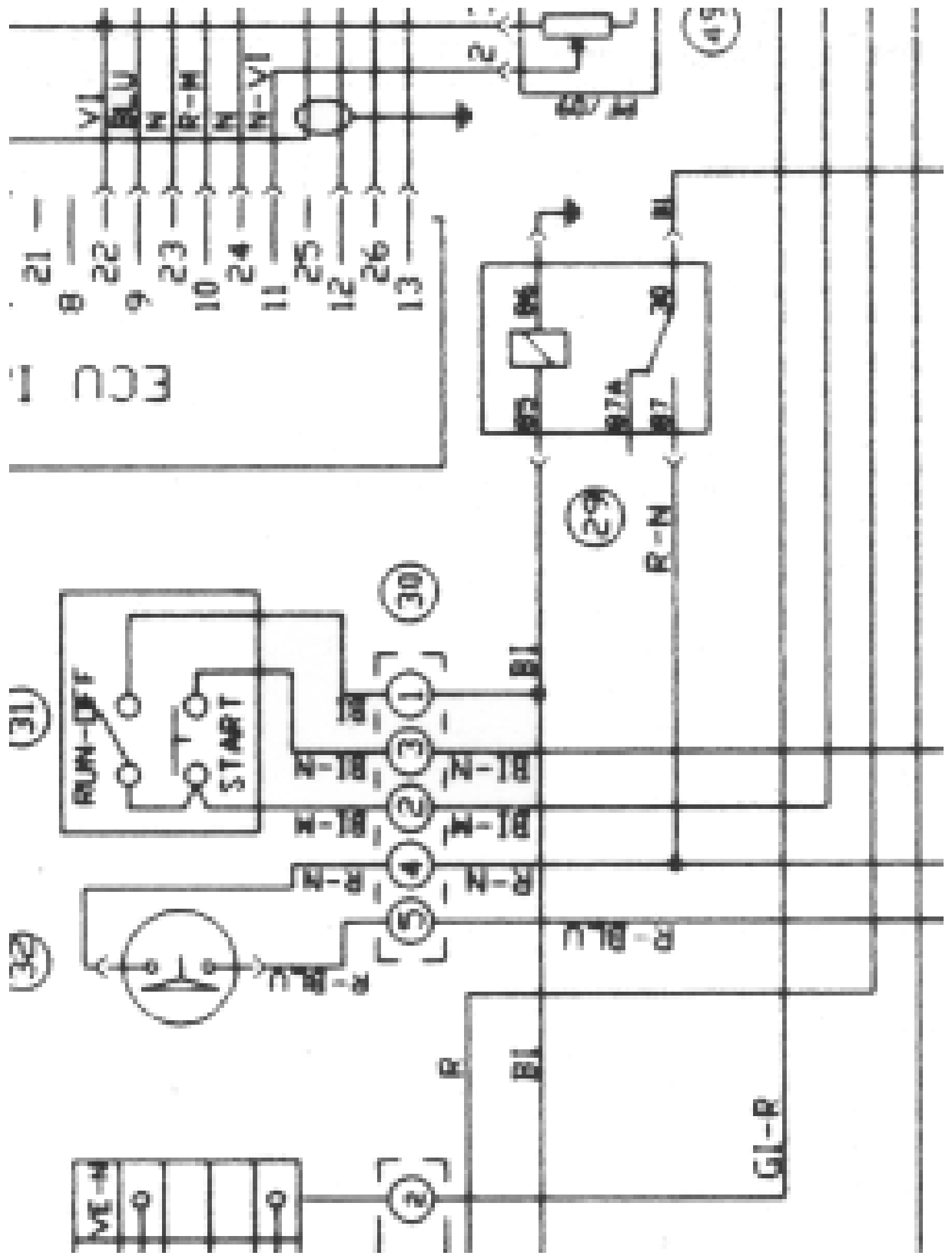

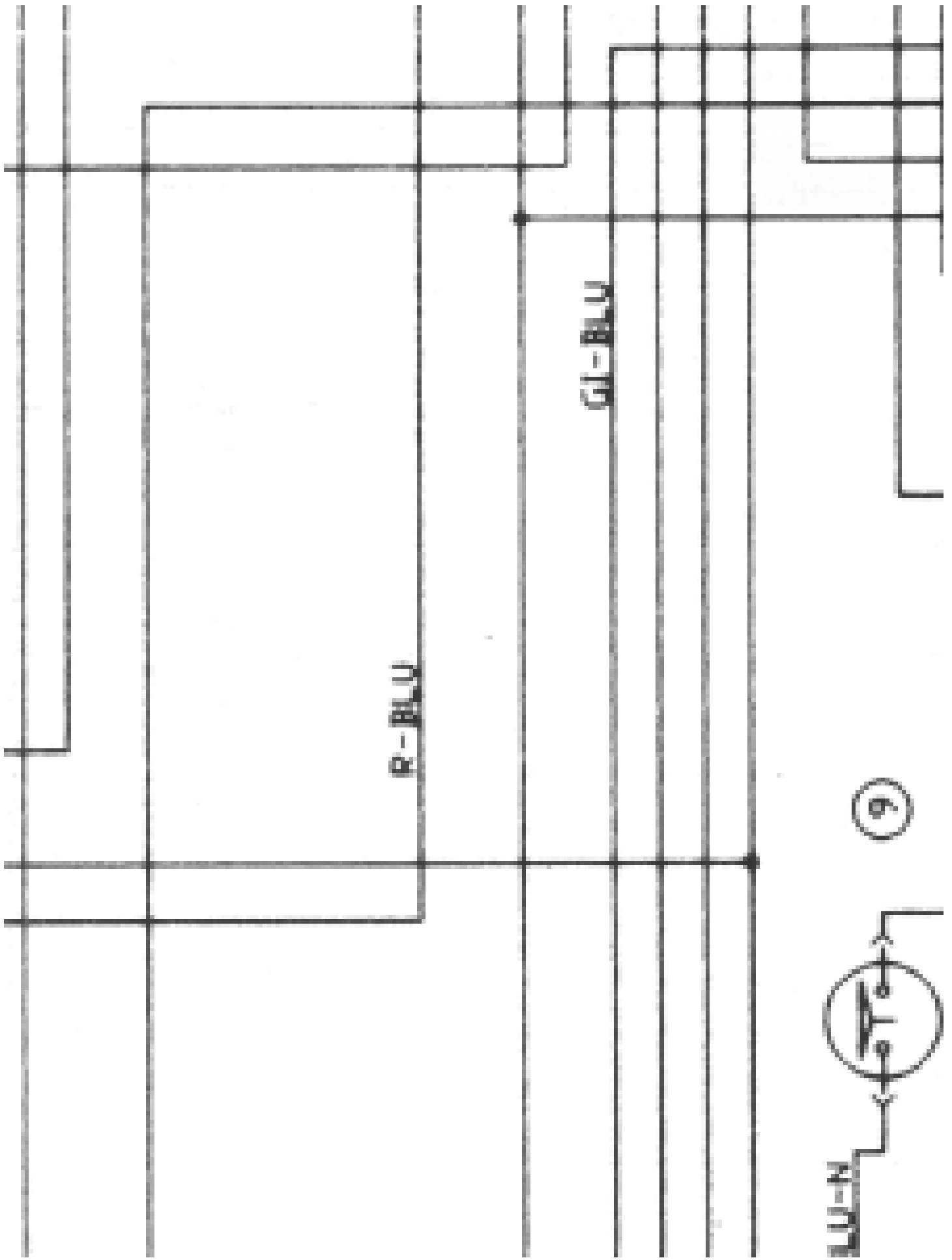

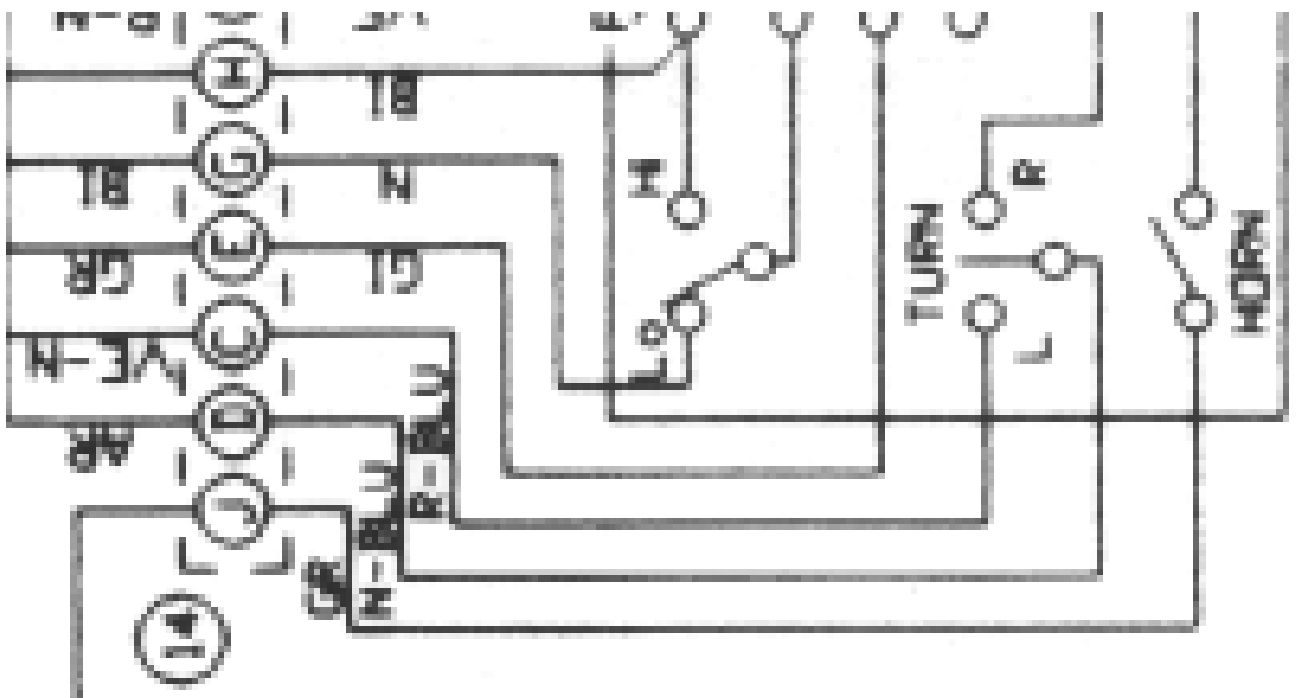
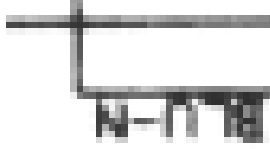
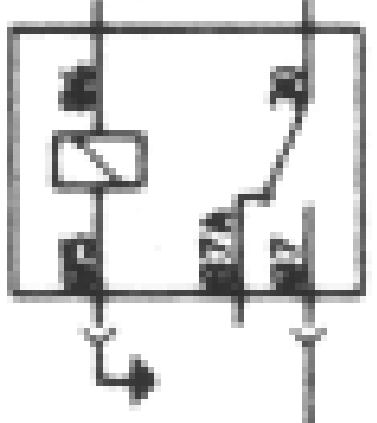
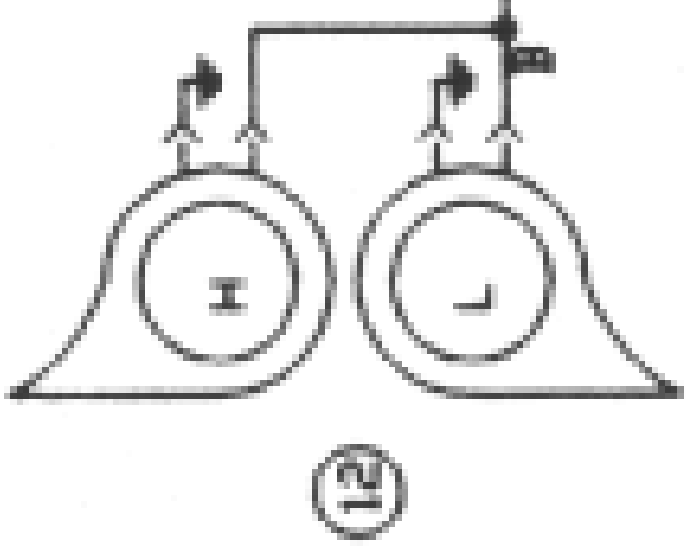
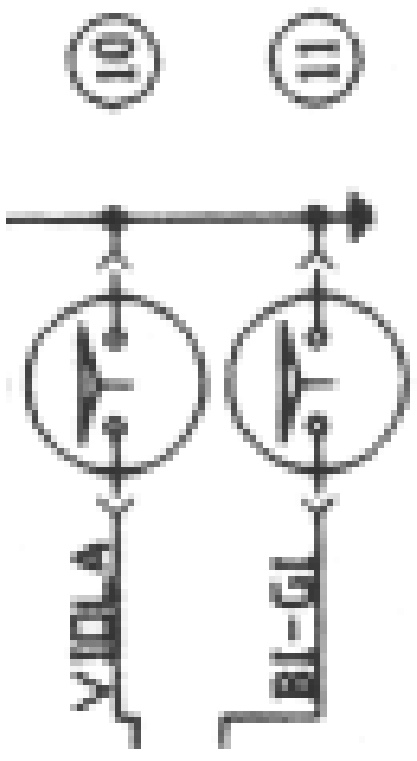

(34)

	VT	MP	GI
P	O		
LOCK			
OFF			
ON	O	O	O

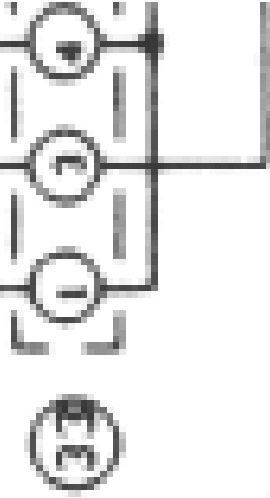

(33)

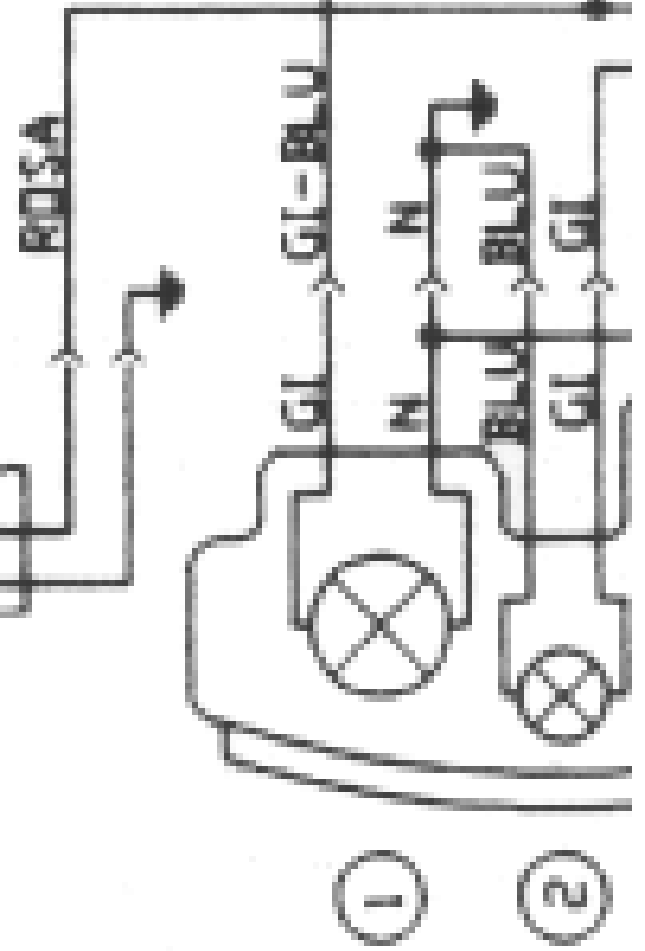
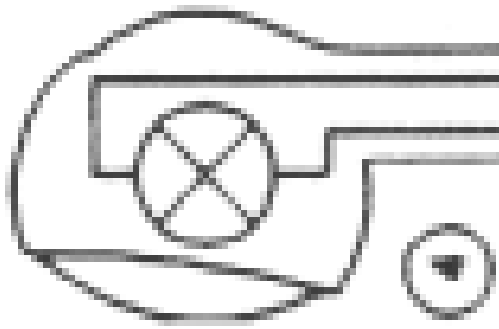

1

2

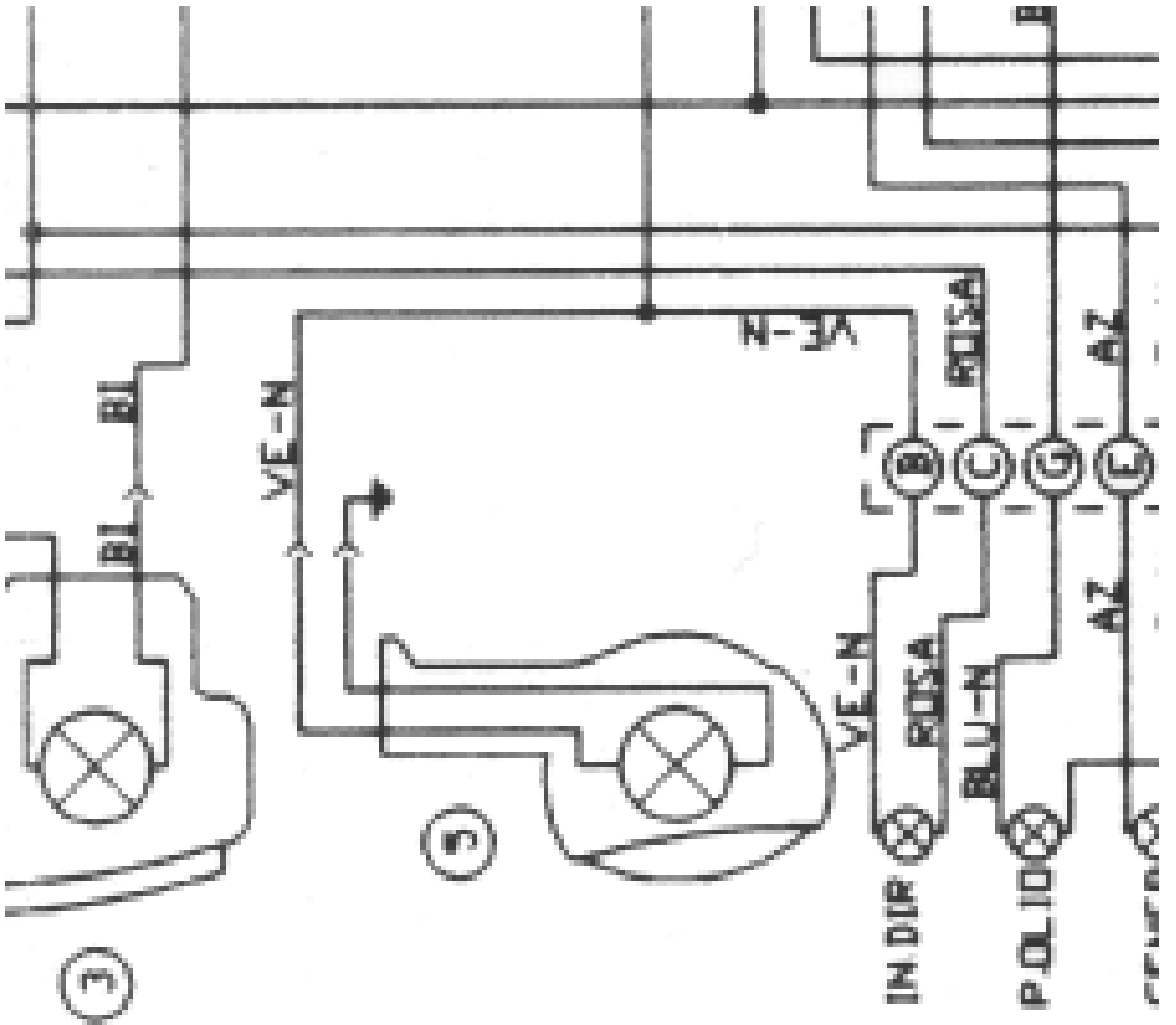

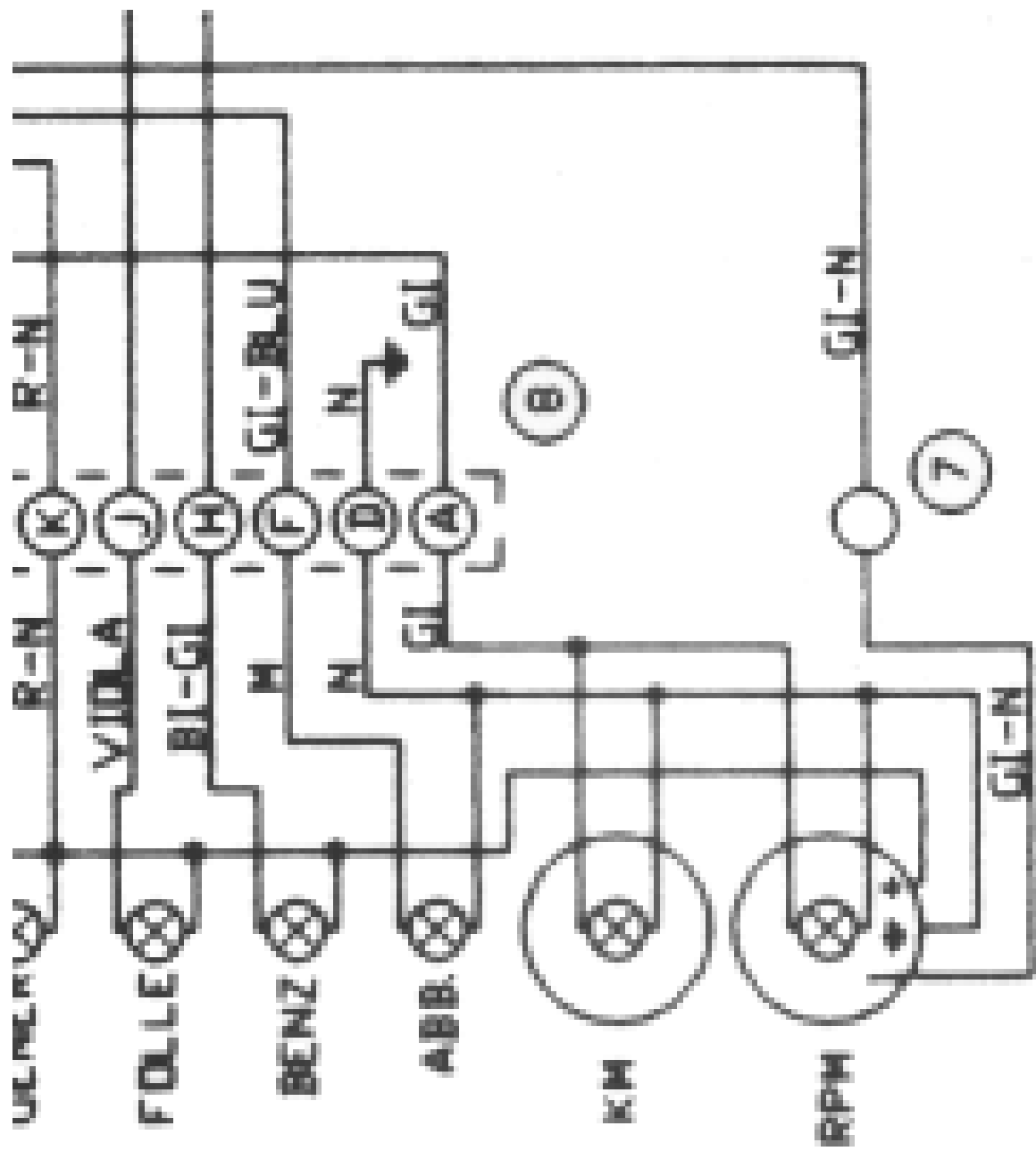

⑥

⑧

⑦