

1989 Moto Guzzi 750 SP

23 October 2005

Carl Allison

Drawing is sized to print as
super A3 (13x19") at 50%

NOTE: Absolutely no guarantee that
wire colors are correct. Original
scan illegible.

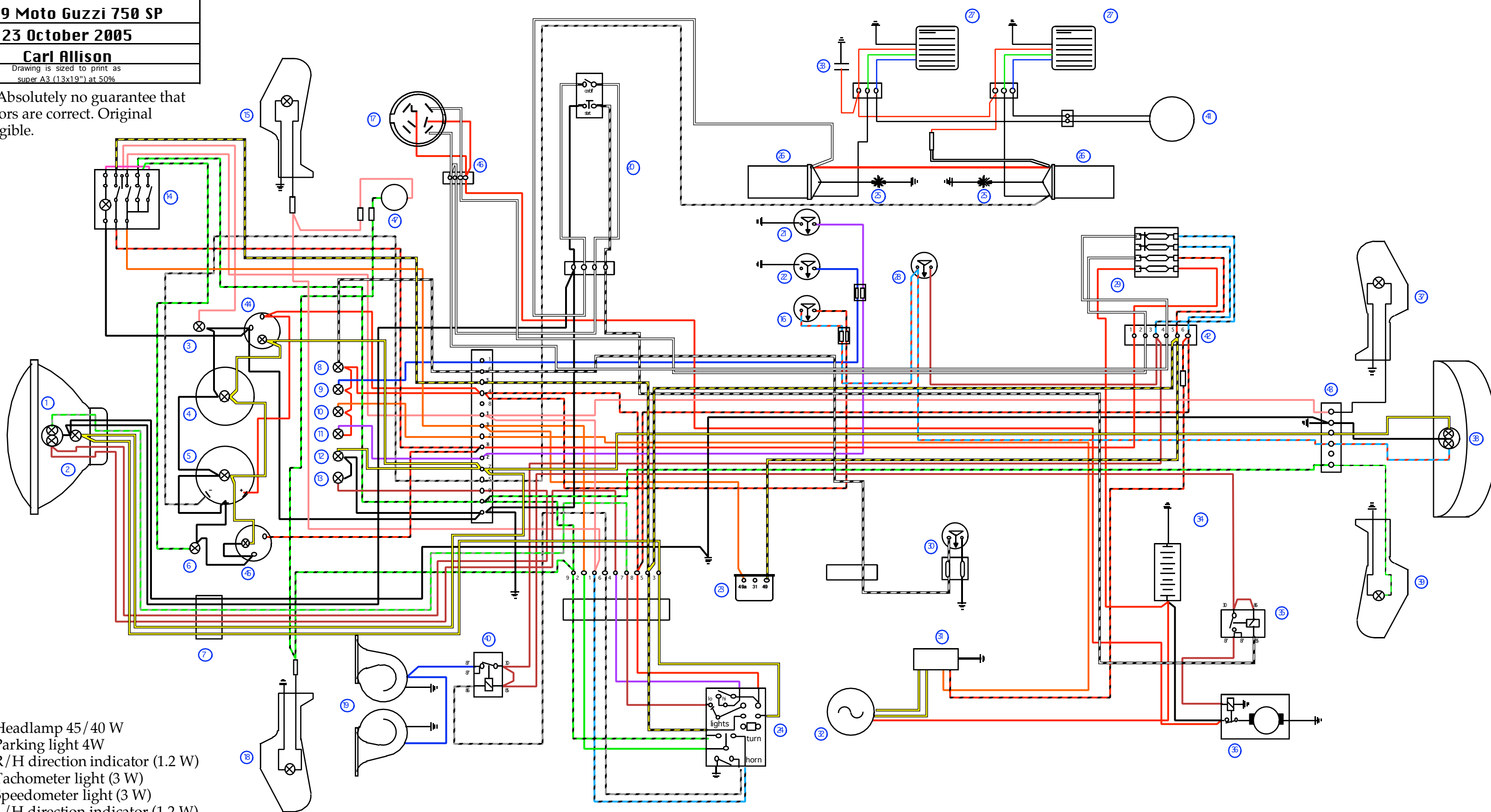

- 1. Headlamp 45/40 W
- 2. Parking light 4W
- 3. R/H direction indicator (1.2 W)
- 4. Tachometer light (3 W)
- 5. Speedometer light (3 W)
- 6. L/H direction indicator (1.2 W)
- 7. Connector, Molex 4-way
- 8. Low fuel warning light (1.2 W)
- 9. Oil pressure light (1.2 W)
- 10. Generator light (1.2 W)
- 11. Neutral indicator (1.2 W)
- 12. Lights indicator (1.2 W)
- 13. High beam indicator (1.2 W)
- 14. Emergency flasher switch
- 15. R/H front turn signal (10 W)
- 16. Front brake switch
- 17. Ignition switch
- 18. L/H front turn signal (10 W)
- 19. Horns, two tone
- 20. Controls, engine start/stop, Run etc

- 21. Neutral switch
- 22. Oil pressure switch
- 23. Flasher (12 V)
- 24. Controls horn, direction indicators headlight
- 25. Spark plugs
- 26. Ignition coils
- 27. Points
- 28. Rear stop switch
- 29. Fuseblock
- 30. Low fuel switch
- 31. Regulator
- 32. Alternator (14V - 20A)
- 33. Condensator
- 34. Battery

- 35. Starter relay
- 36. Starter motor
- 37. R/H rear turn signal (10 W)
- 38. Taillight and stoplight (5/21 W)
- 39. L/H rear turn signal (10 W)
- 40. Horn relay
- 41. Pick-up
- 42. Connector AMP 6-way
- 43. Connector MOLEX 6-way
- 44. Voltmeter
- 45. Clock
- 46. Connector AMP 4-way
- 47. Emergency flasher indicator