

Wiring Color Codes

yellow	white/black
pink	yellow/white
red	red/white
brown	brown/white
orange	blue/white
violet	green/white
blue	grey/red
light blue	grey/green
green	red/yellow
grey	yellow/black

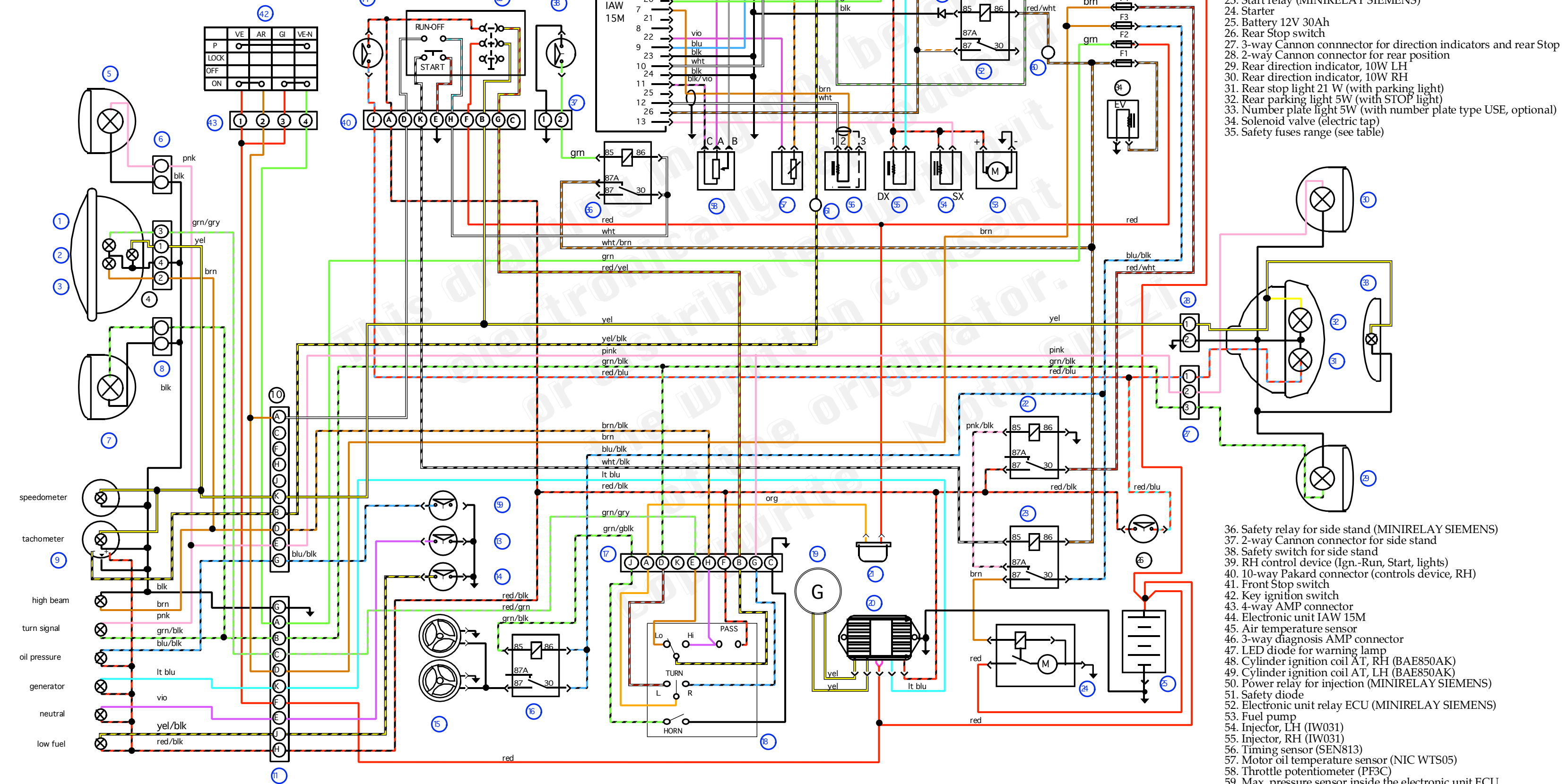
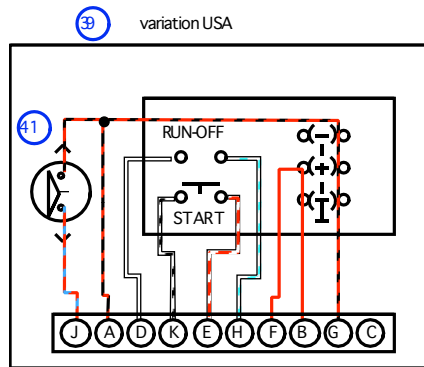

- List of Fuses (All 15A)
- F1. Electric tap
 - F2. Parking lights, direction indicators
 - F3. Starter, horn
 - F4. Driving beam, traffic beam, stop
 - F5. Electron unit ECU
 - F6. Pump, coils, injectors

1. Driving beam 60 W (H4 halogen with traffic beam)
2. Parking light 4W
3. Traffic beam 55W (H4 halogen with driving beam)
4. 4-way AMP connector for front lamp
5. Front direction indicator 10W, RH
6. 2-way Cannon connector for front direction indicator, RH
7. Front direction indicator 10W, LH
8. 2-way Cannon connector for front direction indicator, LH
9. Instrument panel
10. 10-way A Pakard connector (instrument panel)
11. 10-way B Pakard connector (instrument panel)
12. Switch for oil pressure
13. Idle switch
14. Switch for fuel level
15. Horn
16. Horn relay (MINIRELAY SIEMENS)
17. 10-way Pakard connector (device LH)
18. LH control device, lights, direction indicators, horn
19. Alternator, 12V 350W
20. Voltage regulator
21. Intermittence
22. Lights relay (MINIRELAY SIEMENS)
23. Start relay (MINIRELAY SIEMENS)
24. Starter
25. Battery 12V 30Ah
26. Rear Stop switch
27. 3-way Cannon connector for direction indicators and rear Stop
28. 2-way Cannon connector for rear position
29. Rear direction indicator, 10W LH
30. Rear direction indicator, 10W RH
31. Rear stop light 21 W (with parking light)
32. Rear parking light 5W (with STOP light)
33. Number plate light 5W (with number plate type USE, optional)
34. Solenoid valve (electric tap)
35. Safety fuses range (see table)

36. Safety relay for side stand (MINIRELAY SIEMENS)
37. 2-way Cannon connector for side stand
38. Safety switch for side stand
39. RH control device (Ign.-Run, Start, lights)
40. 10-way Pakard connector (controls device, RH)
41. Front Stop switch
42. Key ignition switch
43. 4-way AMP connector
44. Electronic unit IAW 15M
45. Air temperature sensor
46. 3-way diagnosis AMP connector
47. LED diode for warning lamp
48. Cylinder ignition coil AT, RH (BAE850AK)
49. Cylinder ignition coil AT, LH (BAE850AK)
50. Power relay for injection (MINIRELAY SIEMENS)
51. Safety diode
52. Electronic unit relay ECU (MINIRELAY SIEMENS)
53. Fuel pump
54. Injector, LH (IW031)
55. Injector, RH (IW031)
56. Timing sensor (SEN813)
57. Motor oil temperature sensor (NIC WTS05)
58. Throttle potentiometer (PF3C)
59. Max. pressure sensor inside the electronic unit ECU
60. 1-way AMP connector (key closed supply)
61. 1-way AMP connector (RPM sensor in the injection side)