



MOTO GUZZI®

PROUDLY AUTHENTIC MOTORCYCLES. SINCE 1921.

SERVICE STATION MANUAL

2Q000383

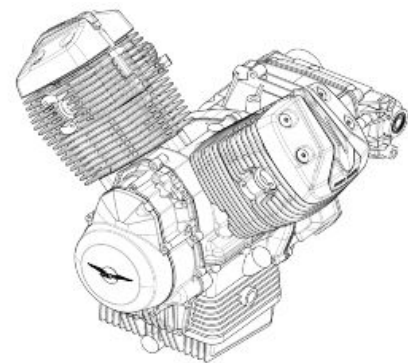

Engine V85 E4



SERVICE STATION MANUAL

Engine V85 E4

THE VALUE OF SERVICE

As a result of continuous updates and specific technical training programmes for Moto Guzzi products, only **Moto Guzzi** Official Network mechanics know this vehicle fully and have the specific tools necessary to carry out maintenance and repair operations correctly.

The reliability of the vehicle also depends on its mechanical conditions. Checking the vehicle before riding it, its regular maintenance and the use of **original Moto Guzzi spare parts** only are essential factors!

For information on the nearest **Official Dealer and/or Service Centre** consult our website:

www.motoguzzi.com

Only by requesting Moto Guzzi original spare parts can you be sure of purchasing products that were developed and tested during the actual vehicle design stage. All Moto Guzzi original spare parts undergo quality control procedures to guarantee reliability and durability.

The descriptions and images in this publication are given for illustrative purposes only and are not binding. While the basic characteristics as described and illustrated in this booklet remain unchanged, Piaggio & C. S.p.A. reserves the right, at any time and without being required to update this publication beforehand, to make any changes to components, parts or accessories, which it considers necessary to improve the product or which are required for manufacturing or construction reasons.

Not all versions/models shown in this publication are available in all countries. The availability of individual versions should be checked with the Official Moto Guzzi sales network.

The Moto Guzzi brand is owned by Piaggio & C. S.p.A.

© Copyright 2021 - Piaggio & C. S.p.A. All rights reserved. Reproduction of this publication in whole or in part is prohibited.

Piaggio & C. S.p.A. Viale Rinaldo Piaggio, 25 - 56025 PONTEDERA (PI), Italy

www.piaggio.com

SERVICE STATION MANUAL

Engine V85 E4

This manual provides the main information to carry out regular maintenance operations on your vehicle. This manual is intended to **Moto Guzzi Dealers** and their qualified mechanics; several concepts have been deliberately omitted as they are considered unnecessary. As it is not possible to include complete mechanical notions in this manual, users should have basic mechanical knowledge or minimum knowledge about the procedures involved when repairing vehicle. Without this knowledge, repairing or checking the vehicle may be inefficient or even dangerous. As the vehicle repair and check procedures are not described in detail, be extremely cautious so as not to damage components or injure individuals. In order to optimise customer satisfaction when using our vehicles, **Piaggio & C. S.p.a.** commits itself to continually improve its products and the relative documentation. The main technical modifications and changes in repair procedures are communicated to all **Moto Guzzi Sales Outlets and its International Subsidiaries**. These changes will be introduced in the subsequent editions of the manual. In case of need or further queries on repair and check procedures, consult **Moto Guzzi CUSTOMER DEPARTMENT**, which will be prepared to provide any information on the subject and any further communications on updates and technical changes related to the vehicle.

NOTE Provides key information to make the procedure easier to understand and carry out.

CAUTION Refers to specific procedures to carry out for preventing damages to the vehicle.

WARNING Refers to specific procedures to carry out to prevent injuries to the repairer.



Personal safety Failure to completely observe these instructions will result in serious risk of personal injury.



Safeguarding the environment Sections marked with this symbol indicate the correct use of the vehicle to prevent damaging the environment.



Vehicle intactness The incomplete or non-observance of these regulations leads to the risk of serious damage to the vehicle and sometimes even the invalidity of the guarantee

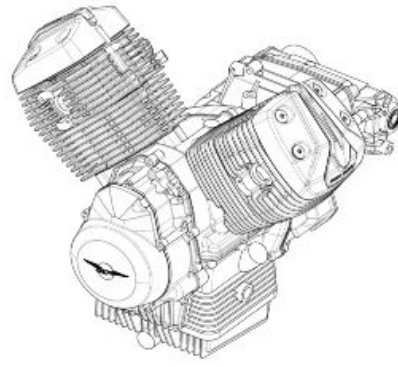

INDEX OF TOPICS

CHARACTERISTICS

CHAR

SPECIAL TOOLS

S-TOOLS

ENGINE

ENG

INDEX OF TOPICS

CHARACTERISTICS

CHAR

Tightening Torques

If the following tables do not expressly indicate the tightening torque values, refer to the table with the generic torque values indicated below.

GENERAL TIGHTENING TORQUES

	M4	M5	M6	M8	M10	M12
Metric tightening torque: TE - TEFL - SHC - TBEI - TCC - TS	3 Nm (2.21 lbf ft)	6 Nm (4.43 lbf ft)	10 Nm (7.38 lbf ft)	25 Nm (18.44 lbf ft)	50 Nm (36.88 lbf ft)	80 Nm (59.00 lbf ft)

GENERAL TIGHTENING TORQUES FOR SELF TAPPING SCREWS FOR PLASTIC

	2.9 mm	3.9 mm	4.2 mm	5 mm
Tightening torque	2 Nm (1.48 lbf ft)	2 Nm (1.48 lbf ft)	3 Nm (2.21 lbf ft)	3 Nm (2.21 lbf ft)

CAUTION

THE SCREWS WITH THREAD-LOCK SEALANT (PRE-IMPREGNATED) MUST BE REPLACED WITH NEW SCREWS AFTER THEY HAVE BEEN LOOSENED. BEFORE FITTING THE NEW SCREWS, CLEAN THE THREADED HOLES CAREFULLY, MAKING SURE THAT ALL TRACES OF THE OLD THREAD-LOCK SEALANT HAVE BEEN ELIMINATED.

Engine

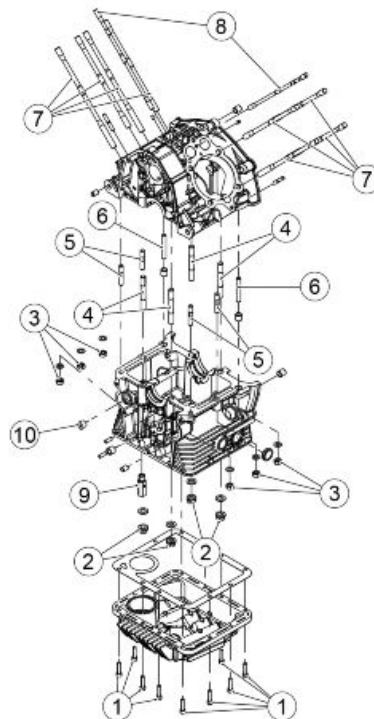

CARTERS

Pos.	Description	Type	Quantity	Torque	Note
1	Oil sump SHC screws	M6	2	11-13 Nm (8.11-9.59 lbf ft)	-
2	Crankcase half flanged nuts (pre-tightening)	M10	4	22-27 Nm (16.23-19.91 lbf ft)	-
2	Crankcase half flanged nuts (final tightening)	M10	4	44-49 Nm (32.45-36.14 lbf ft)	-

Pos.	Description	Type	Quantity	Torque	Note
3	Crankcase half nuts	M8	6	22-25 Nm (16.23-18.44 lb ft)	-
4	Crankcase half stud bolts	M10	4	22-25 Nm (16.23-18.44 lb ft)	Pre-applied Loct.; alternatively Loct. 2510
5	Crankcase half stud bolts	M8	4	22-25 Nm (16.23-18.44 lb ft)	Loct. 648
6	Crankcase half stud bolts	M8	2	22-25 Nm (16.23-18.44 lb ft)	Loct. 648
7	Long/short head stud bolts	M10	8	9-11 Nm (6.64-8.11 lb ft)	Pre-applied Loct.; alternatively Loct. DRI-LOC 211 / 3M SCOTCH GRIP 2510
8	Central head stud bolts	M8	2	9-11 Nm (6.64-8.11 lb ft)	Pre-applied Loct.; alternatively Loct. DRI-LOC 211 / 3M SCOTCH GRIP 2510
9	Oil filter joint	M12	1	20-24 Nm (14.75-17.70 lb ft)	-
10	Cap	M14	1	15-19 Nm (11.06-14.01 lb ft)	Pre-applied Loct. - LOCTITE DRI-SEAL 506 alternatively LOCTITE 5061 - Regularly check that the cap is at the same level with the surface

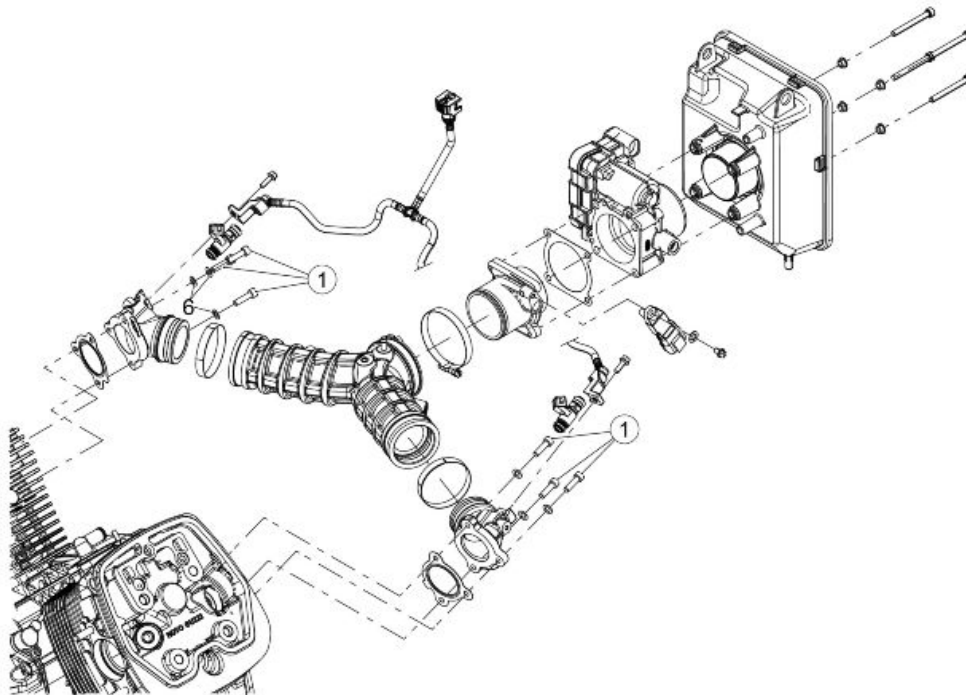

THROTTLE BODY

Pos.	Description	Type	Quantity	Torque	Note
1	Intake fittings screws	M6x22	6	9-11 Nm (6.64-8.11 lb ft)	-

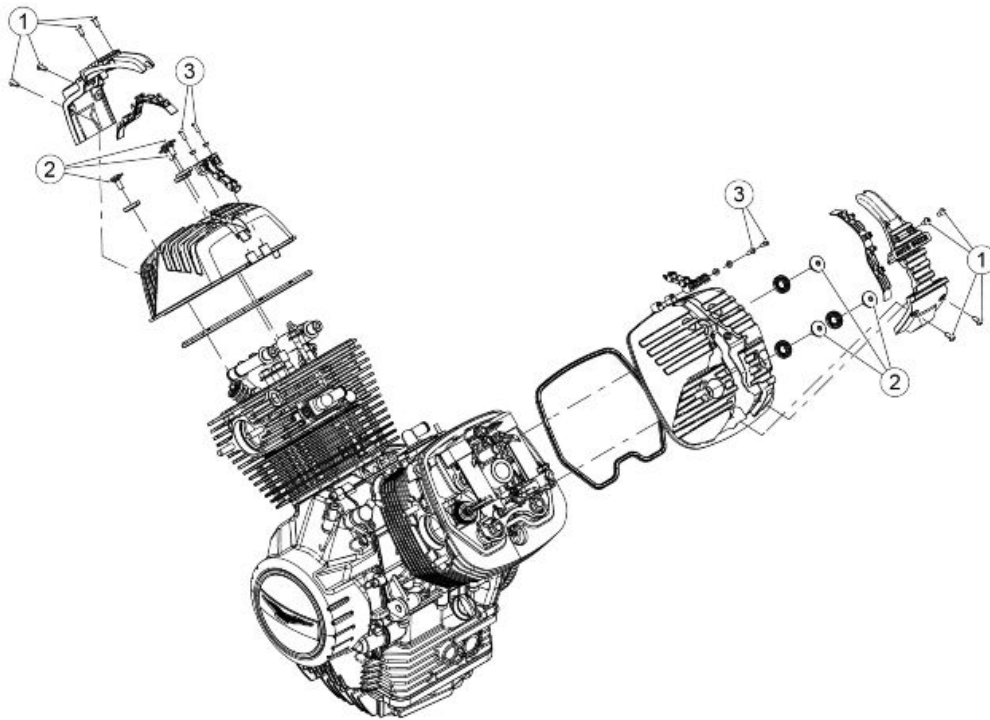

HEADS COVERS

Pos.	Description	Type	Quantity	Torque	Note
1	Spark plugs cover hex socket screws	M5x12	8	6-8 Nm (4.42-5.90 lb ft)	-
2	Head covers screws	M6	6	9-11 Nm (6.64-8.11 lb ft)	-
3	Rounded head torx screws for spark plugs cable clamp on head covers	M4	4	2.6-3.1 Nm (1.92-2.29 lb ft)	-
-	Spark plugs	-	2	10-12 Nm (7.38-8.85 lb ft)	-

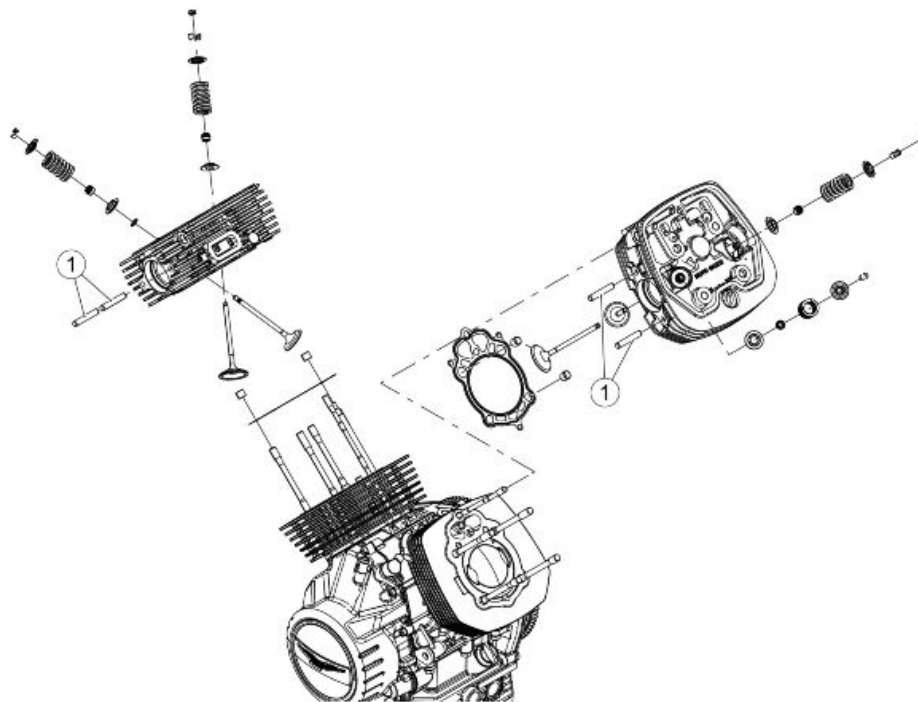

HEAD - VALVES

Pos.	Description	Type	Quantity	Torque	Note
1	Stud bolts for exhaust manifolds	M8	4	20-24 Nm (14.75-17.70 lb ft)	-

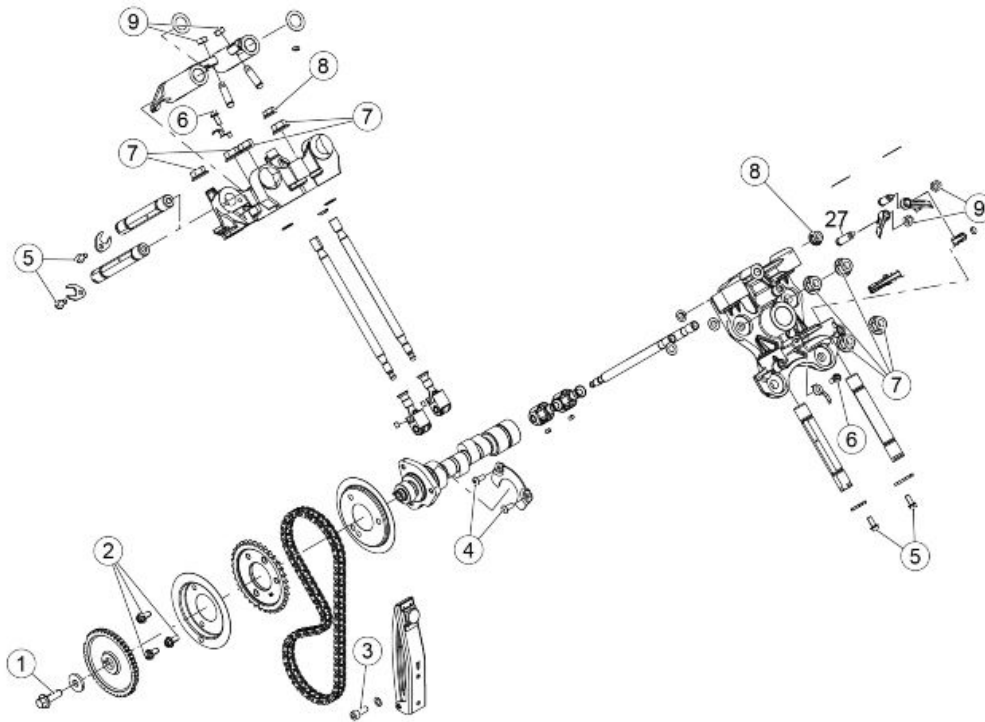

TIMING SYSTEM

Pos.	Description	Type	Quantity	Torque	Note
1	Tone wheel flanged hex head screw	M7x18	1	16-17 Nm (11.80-12.54 lb ft)	Pre-applied Loct. - 3M SCOTCH-GRIP 2363 or PRELOK PRECOTE 80 or Loct. 2048
2	Timing system sprocket flanged hex head screws	M6	3	9-11 Nm (6.64-8.11 lb ft)	Pre-applied Loct.; alternatively 3M SCOTCH-GRIP 2353
3	Chain tensioner screw	M6	1	9-11 Nm (6.64-8.11 lb ft)	-
4	Camshaft retainer plate torx rounded head screws	M5x12	2	6-7 Nm (4.42-5.16 lb ft)	Pre-applied Loct.; alternatively 3M SCOTCH-GRIP 2353
5	Rocker axles forks hex head flanged screws	M5x12	4	5-6 Nm (3.69-4.42 lb ft)	Loct. 243
6	Flanged HH screws for ground plates on rocker supports	M5x12	2	5-6 Nm (3.69-4.42 lb ft)	Loct. 243
7	Stud bolt fixing nuts (pre-tightening)	M10	8	13-16.6 Nm (9.59-12.24 lb ft)	Lubricate the threads and the support surface with MOLYCOTE GRAPID PLUS SPRAY grease
7	Stud bolt fixing nuts (final tightening)	M10	8	87°-93° - 24-34 Nm (17.70-25.08 lbf ft)	Lubricate the threads and the support surface with MOLYCOTE GRAPID PLUS SPRAY grease

Pos.	Description	Type	Quantity	Torque	Note
8	Stud bolt fixing nut (pre-tightening)	M8	2	9-11.5 Nm (6.64-8.48 lbf ft)	Lubricate the threads and the support surface with MOLYCOTE GRAPID PLUS SPRAY grease
8	Stud bolt fixing nut (final tightening)	M8	2	88°-92° - 14-18 Nm (10.32-13.28 lbf ft)	Lubricate the threads and the support surface with MOLYCOTE GRAPID PLUS SPRAY grease

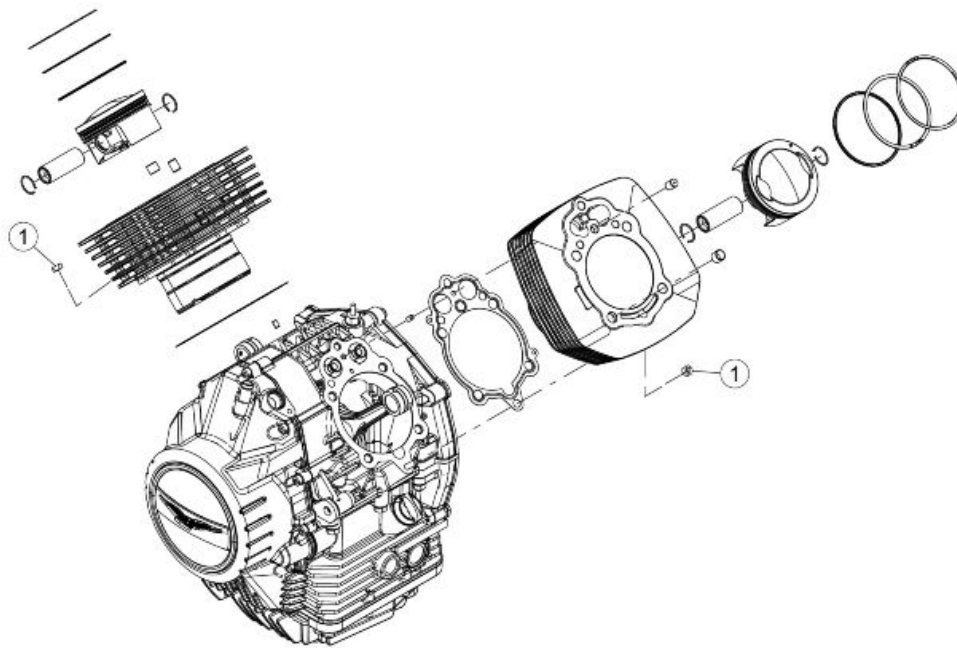

CYLINDER - PISTON

Pos.	Description	Type	Quantity	Torque	Note
1	Cylinder nut	M6	2	9-11 Nm (6.64-8.11 lbf ft)	Loct. 243

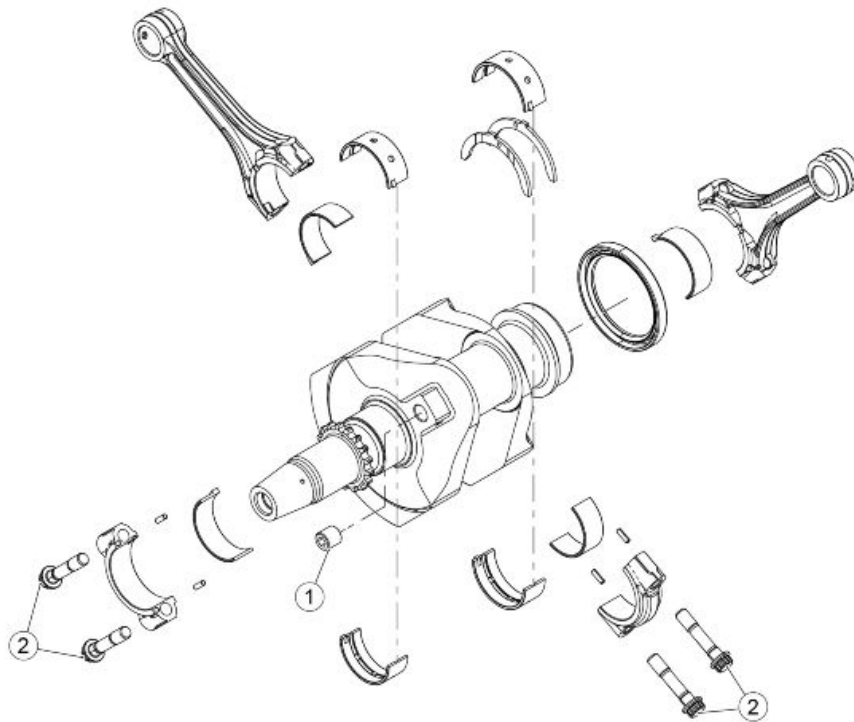

CRANKSHAFT

Pos.	Description	Type	Quantity	Torque	Note
1	Crankshaft plug	M12	1	15-18 Nm (11.06-13.28 lb ft)	Loct. 648
2	Connecting rods screws (pre-tightening 1st coupling)	M8	4	10 Nm (7.37 lb ft)	Lubricate the thread and underhead with Pankl PLB 19
2	Connecting rods screws (pre-tightening 2nd coupling)	M8	4	20 Nm (14.75 lbf ft)	Lubricate the thread and underhead with Pankl PLB 19
2	Connecting rods screws (final tightening)	M8	4	65°+/-2° - 40-70 Nm (29.50-51.73 lbf ft)	Lubricate the thread and underhead with Pankl PLB 19

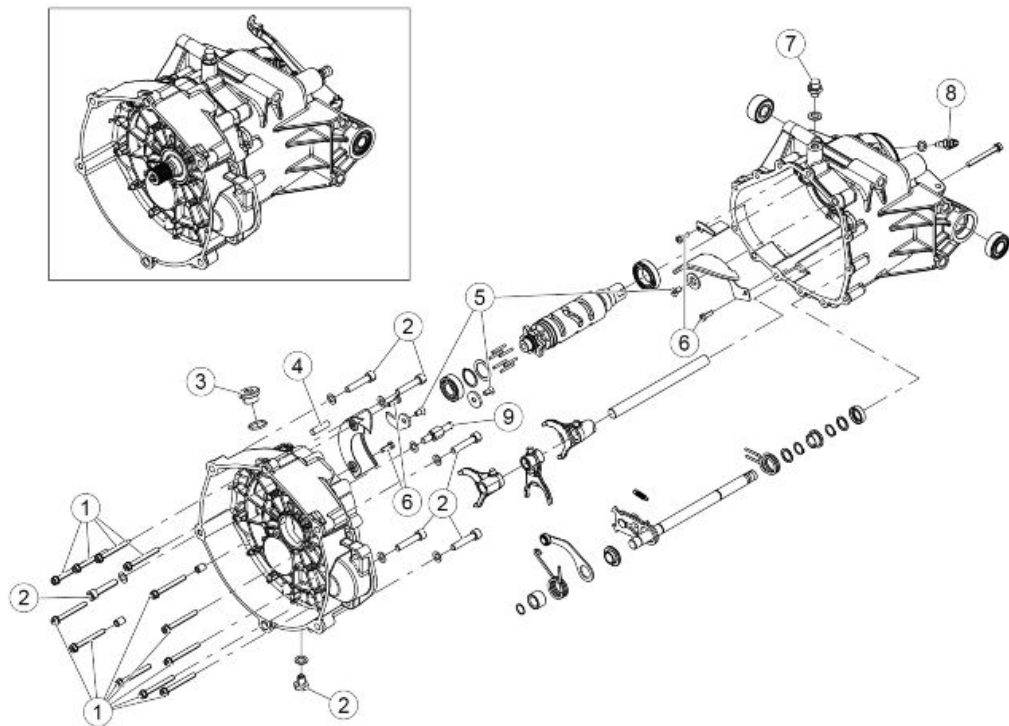

COMPLETE GEAR / SELECTOR / DESMODROMIC

Pos.	Description	Type	Quantity	Torque	Note
1	Clutch housing/gearbox fastening SHC screws	M6x55	13	9-11 Nm (6.64-8.11 lb ft)	-
2	Engine / gearbox fastening SHC screws	M8x40	6	24-28 Nm (17.70-20.65 lb ft)	-
3	Oil load cap	M20	1	23-27 Nm (16.96-19.91 lb ft)	-
4	Threaded pin for ground cable screw	M8x30	1	9-11 Nm (6.64-8.11 lb ft)	Loct. 243
5	Bearing stoppers countersunk hex head screws	M6x12	5	9-11 Nm (6.64-8.11 lb ft)	Pre-applied Loct.; alternatively 3M SCOTCH-GRIP 2353 or Loct. DRI LOC 2045 BLU
6	Oil duct plates Torx screws	M5x16	4	9-11 Nm (6.64-8.11 lb ft)	Pre-applied Loct.; alternatively Loct. 20450 or 3M or 2353
7	Bleeder cap	M10	1	18-22 Nm (13.28-16.23 lb ft)	-
8	Neutral switch	M8	1	9-11 Nm (6.64-8.11 lb ft)	-

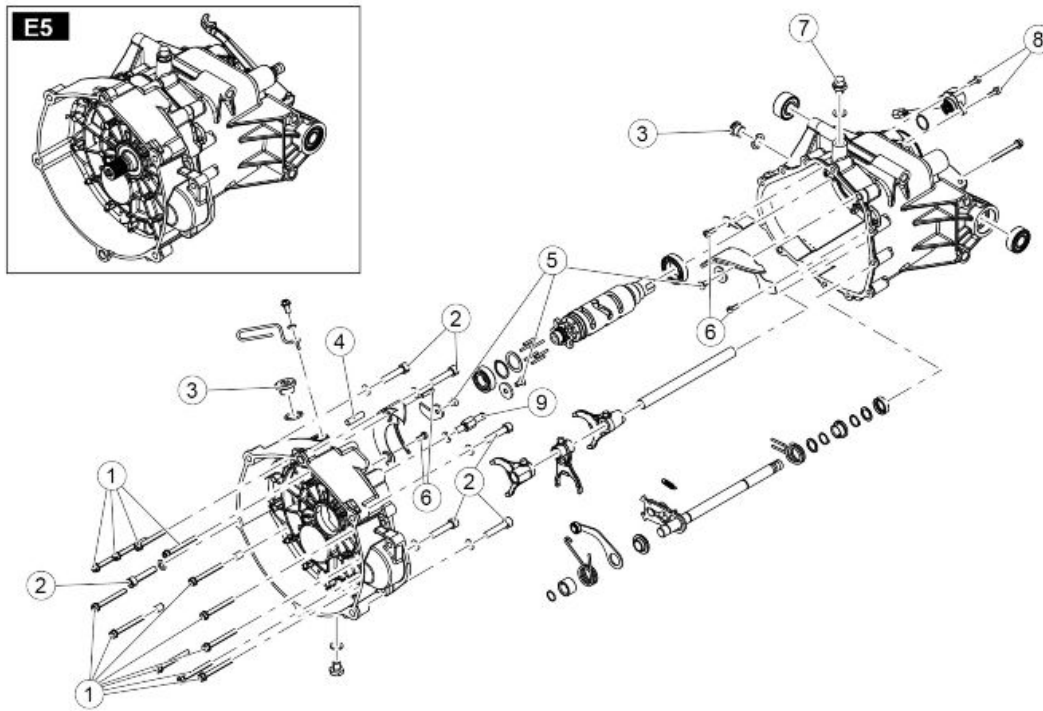

COMPLETE GEAR / SELECTOR / DESMODROMIC E5

Pos.	Description	Type	Quantity	Torque	Note
1	Clutch housing/gearbox fastening SHC screws	M6x55	13	9-11 Nm (6.64-8.11 lb ft)	-
2	Engine / gearbox fastening SHC screws	M8x40	6	24-28 Nm (17.70-20.65 lb ft)	-
3	Oil load cap	M20	1	23-27 Nm (16.96-19.91 lb ft)	-
4	Threaded pin for ground cable screw	M8x30	1	9-11 Nm (6.64-8.11 lb ft)	Loct. 243
5	Bearing stoppers countersunk hex head screws	M6x12	5	9-11 Nm (6.64-8.11 lb ft)	Pre-applied Loct.; alternatively 3M SCOTCH-GRIP 2353 or Loct. DRI LOC 2045 BLU
6	Oil duct plates Torx screws	M5x16	3	6-7 Nm (4.23-5.16 lb ft)	Pre-applied Loct.; alternatively Loct. 20450 or 3M or 2353
7	Bleeder cap	M10	1	18-22 Nm (13.28-16.23 lb ft)	-
8	Gear sensor fastening flanged hex head screw	M5x20	2	6-7 Nm (4.23-5.16 lb ft)	-

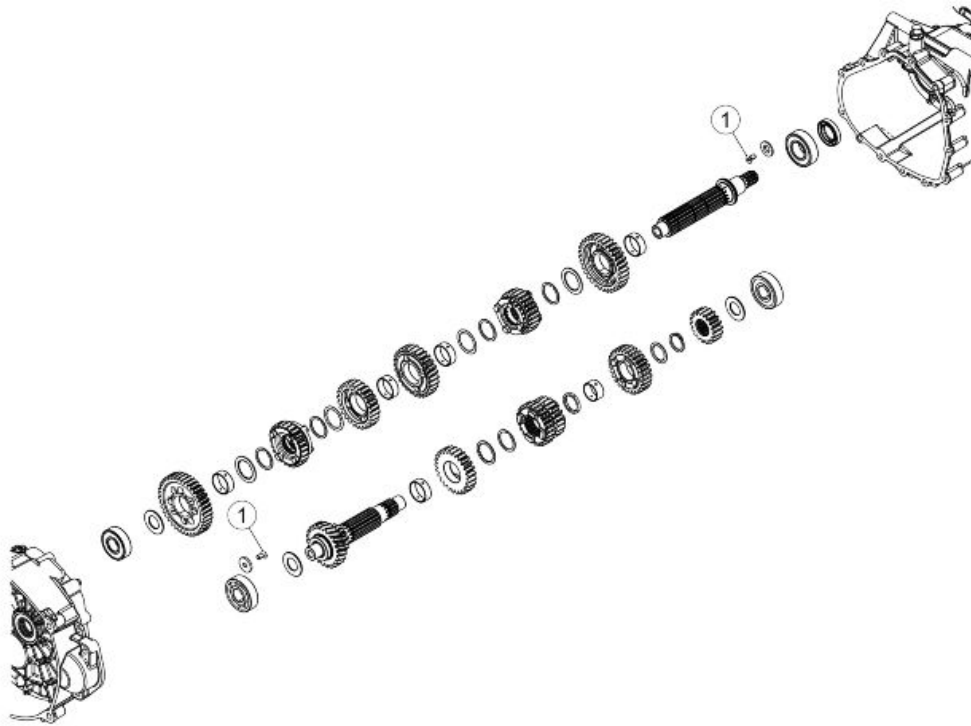

GEARBOX COMPONENTS

Pos.	Description	Type	Quantity	Torque	Note
1	Bearing stoppers countersunk hex head screws	M6x12	2	9-11 Nm (6.64-8.11 lb ft)	Pre-applied Loct.; alternatively 3M SCOTCH-GRIP 2353 or Loct. DRI LOC 2045 BLU

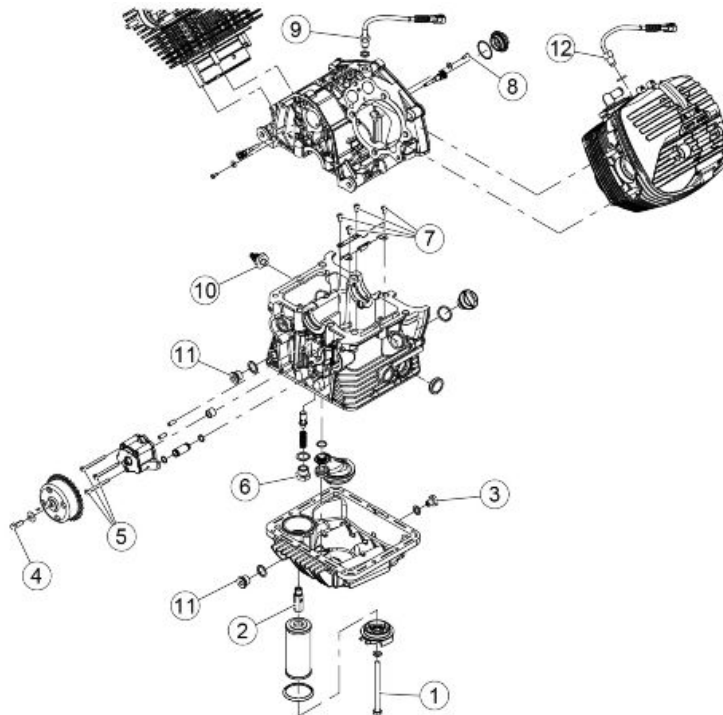

LUBRICATION

Pos.	Description	Type	Quantity	Torque	Note
1	Cover and oil filter cartridge fixing hex head screw	M8x105	1	18-22 Nm (13.28-16.23 lb ft)	-
2	Oil filter joint	M12	1	20-24 Nm (14.75-17.70 lb ft)	-
3	Oil sump drainage plug	M10	1	20-24 Nm (14.75-17.70 lb ft)	-
4	Oil pump gear flanged hex head screw	M7x18	1	13-14 Nm (9.59-10.32 lb ft)	Pre-applied Loct.; alternatively 3M SCOTCH-GRIP 2353
5	Oil pump countersunk head screws	M5x55	3	5-6 Nm (3.69-4.42 lb ft)	3M SCOTCH GRIP 2353
6	Oil pressure valve cap	M18	1	20-25 Nm (14.75-18.44 lb ft)	-
7	Oil scraper plate notched cylindrical head screws	M5x10	4	3-4 Nm (2.21-2.95 lb ft)	Pre-applied Loct.; alternatively 3M SCOTCH-GRIP 2353
8	Cooling jet torx screw	M4x12	2	2.6-3.4 Nm (1.92-2.51 lb ft)	Pre-applied Loct.; alternatively 3M SCOTCH-GRIP 2353 or Loct. DRI LOC 2045 BLU
9	Oil temperature sensor	M10	1	18-22 Nm (13.28-16.23 lb ft)	Loct. 243
10	Minimum oil pressure sensor	-	1	20-24 Nm (14.75-17.70 lb ft)	-
-	Cable screw on the minimum oil pressure sensor	M4	1	1.5-1.8 Nm (1.11-1.33 lb ft)	-
11	Caps	M16	2	28-32 Nm (20.65-23.60 lb ft)	-
12	Engine temperature sensor	M10	1	18-22 Nm (13.28-16.23 lb ft)	Loct. 243

E5

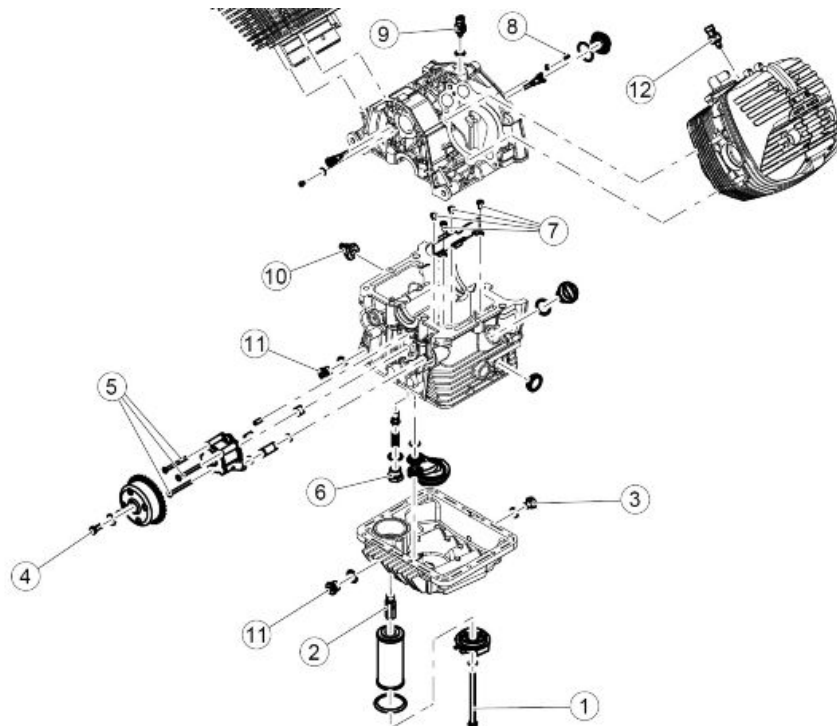

E5 LUBRICATION

Pos.	Description	Type	Quantity	Torque	Note
1	Cover and oil filter cartridge fixing hex head screw	M8x105	1	18-22 Nm (13.28-16.23 lb ft)	-
2	Oil filter joint	M12	1	20-24 Nm (14.75-17.70 lb ft)	-
3	Oil sump drainage plug	M10	1	20-24 Nm (14.75-17.70 lb ft)	-
4	Oil pump gear flanged hex head screw	M7	1	16-17 Nm (9.59-10.32 lb ft)	Pre-applied Loct.; alternatively 3M SCOTCH-GRIP 2353, Loctite 2045 or PRELOX PRE-COTE 80
5	Oil pump countersunk head screws	M5x55	3	5-6 Nm (3.69-4.42 lb ft)	3M SCOTCH GRIP 2353
6	Oil pressure valve cap	M18	1	20-25 Nm (14.75-18.44 lb ft)	-
7	Oil scraper plate notched cylindrical head screws	M5x10	4	3-4 Nm (2.21-2.95 lb ft)	Pre-applied Loct.; alternatively 3M SCOTCH-GRIP 2353, Loctite 2045 or PRELOX PRE-COTE 80
8	Cooling jet torx screw	M4x12	2	2.8-3.4 Nm (2.07-2.51 lb ft)	Pre-applied Loct.; alternatively 3M SCOTCH-GRIP 2353 or Loct. DRI LOC 2045 BLU
9	Oil temperature sensor	M10X1	1	18-22 Nm (13.28-16.23 lb ft)	
10	Minimum oil pressure sensor	-	1	20-24 Nm (14.75-17.70 lb ft)	-
-	Cable screw on the minimum oil pressure sensor	M4	1	1.5-1.8 Nm (1.11-1.33 lb ft)	-
11	Caps	M16	2	28-32 Nm (20.65-23.60 lb ft)	-
12	Engine temperature sensor	M10	1	18-22 Nm (13.28-16.23 lb ft)	

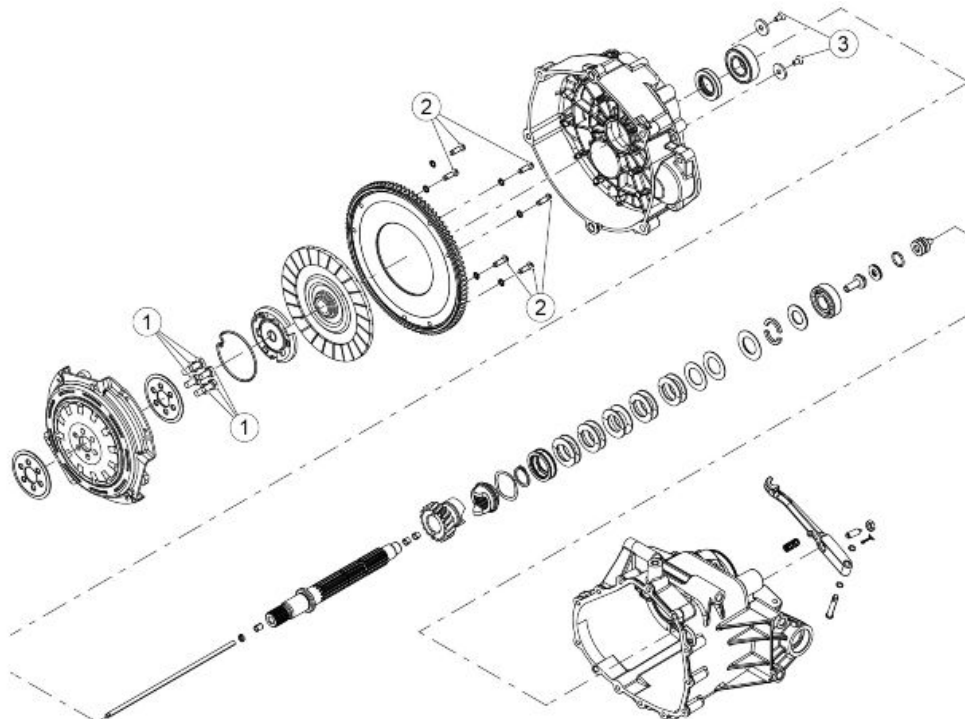

CLUTCH

Pos.	Description	Type	Quantity	Torque	Note
1	Clutch-crankshaft screws	M8	6	38-42 Nm (28.03-30.98 lb ft)	Loct. 243
2	Starter sprocket fixing torx rounded head screws	M6x20	6	9-11 Nm (6.64-8.11 lb ft)	Pre-applied Loct.; alternatively Loct. DRI-LOC 2040 or 3M SCOTCH GRIP 2353
3	Bearing stopper countersunk hex head screws	M6x12	2	9-11 Nm (6.64-8.11 lb ft)	Pre-applied Loct.; alternatively 3M SCOTCH-GRIP 2353 or Loct. DRI LOC 2045 BLU

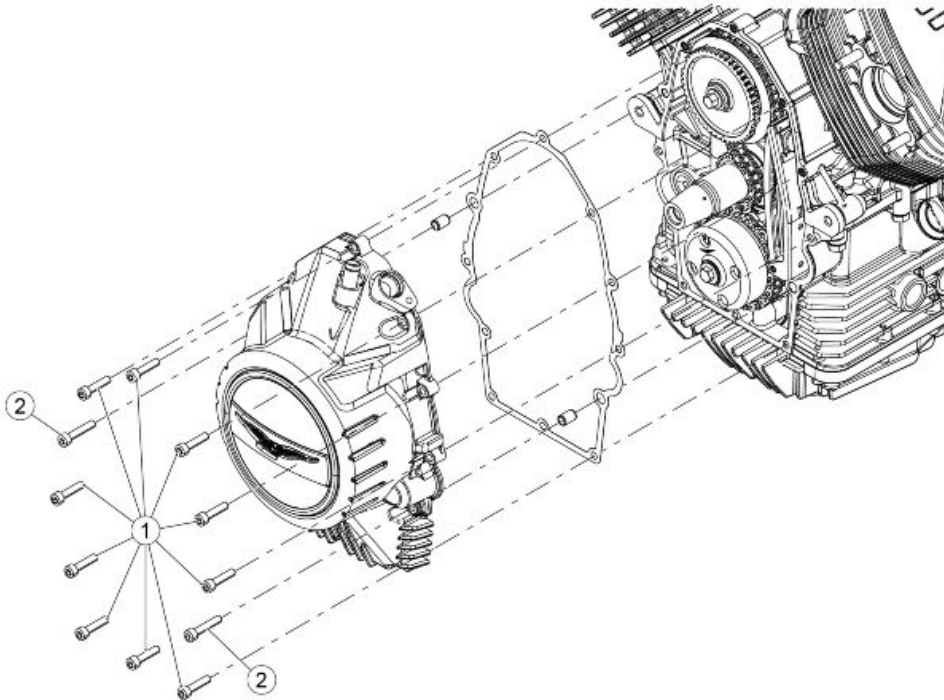

FLYWHEEL COVER

Pos.	Description	Type	Quantity	Torque	Note
1	Flywheel cover SHC screws	M6x25	10	11-13 Nm (8.11-9.59 lb ft)	-
2	Flywheel cover SHC screws	M6x20	2	11-13 Nm (8.11-9.59 lb ft)	-

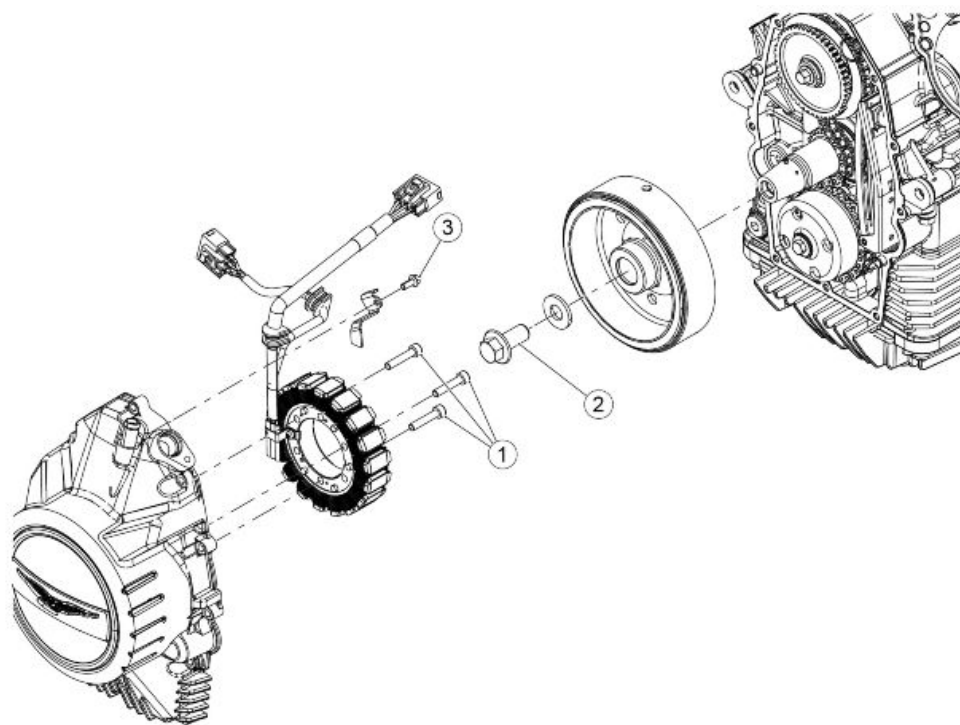

E5

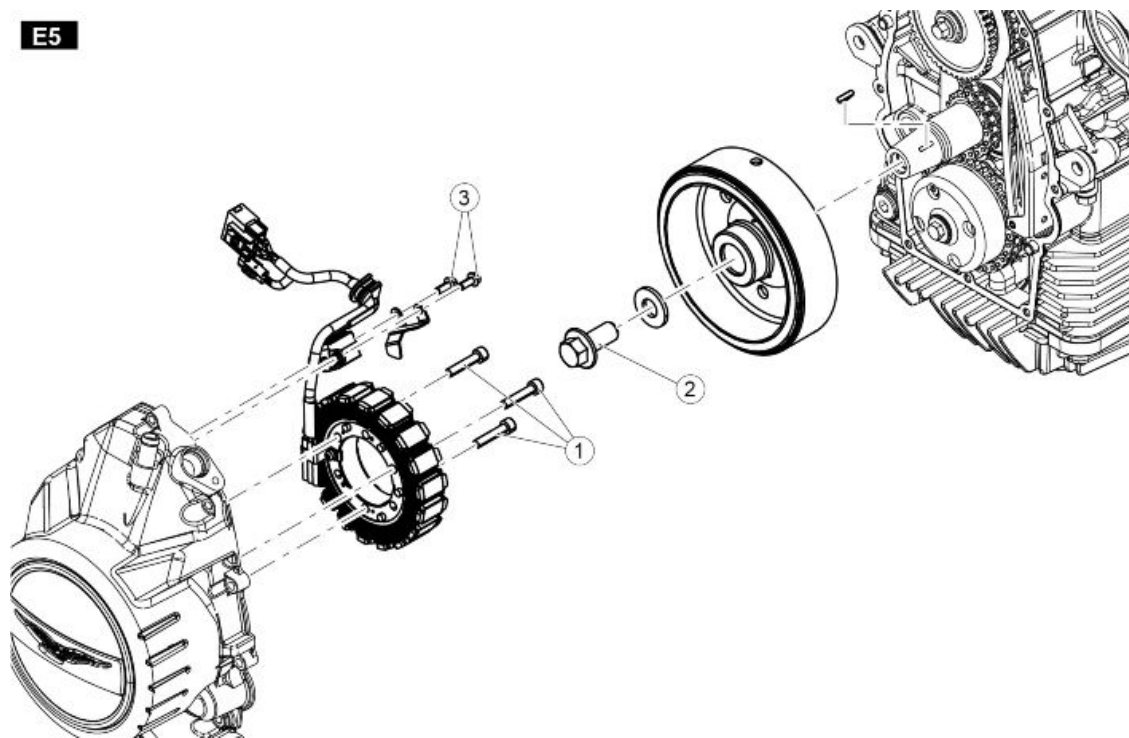

MAGNETO FLYWHEEL / START-UP

Pos.	Description	Type	Quantity	Torque	Note
1	Stator SHC screws	M6x20	3	9-11 Nm (6.64-8.11 lb ft)	Loct. 243
2	Flywheel flanged hex head screw	M14x30	1	114-125 Nm (84.08-92.19 lb ft)	-
3	Flanged hex head screws for cable clamp plate on the generator's cover	M5x12	1	5-6 Nm (3.69-4.42 lb ft)	-

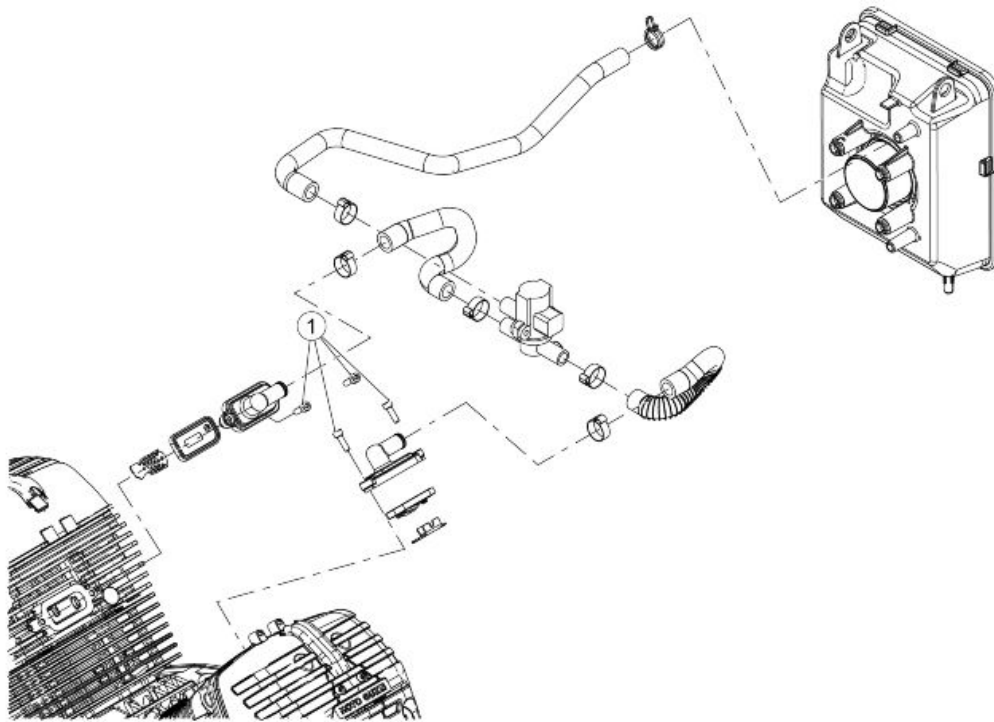

SECONDARY AIR SYSTEM





Pos.	Description	Type	Quantity	Torque	Note
1	Secondary air covers SHC screws	M5	4	3-4 Nm (2.21-2.95 lb ft)	-

INDEX OF TOPICS

SSPECIAL TOOLS

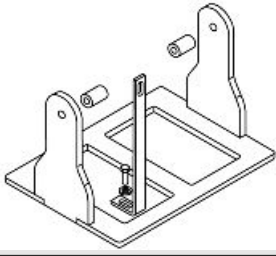
S-TOOLS

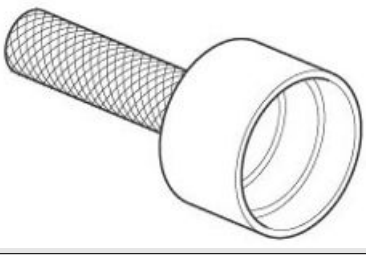
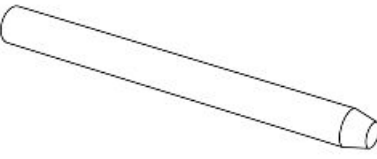
SPECIAL TOOLS

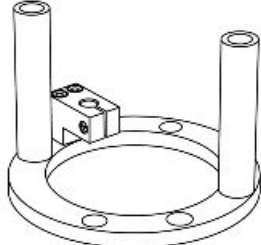
Stores code	Description	
020997Y	Engine support plate	
020382Y	Tool to extract valve cotters	
GU19927100	Tool for mounting seal ring on flange on the flywheel side	
020995Y	Rocker arm centring pin	
020128Y	Piston fitting ring	
020996Y	Piston protrusion measurement tool	

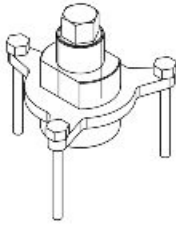
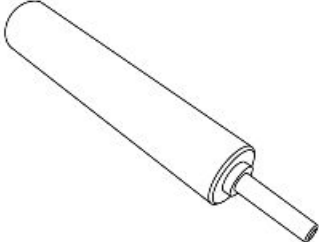
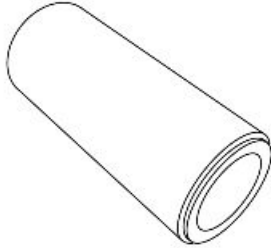
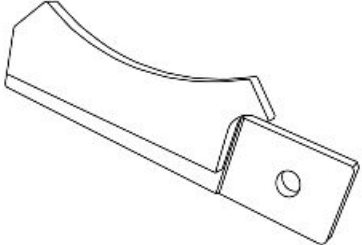
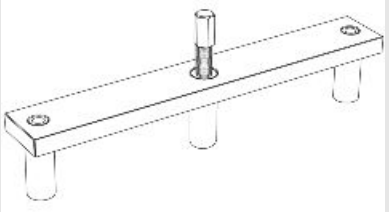
Stores code	Description	
020713Y	Flywheel extractor	
020976Y	Clutch control dust guard mounting punch	
021020Y	Clutch housing oil seal mounting punch	
021001Y	Clutch retainer tool	
021002Y	Clutch centring	

INDEX OF TOPICS

ENGINE

ENG

Gearbox

Diagram

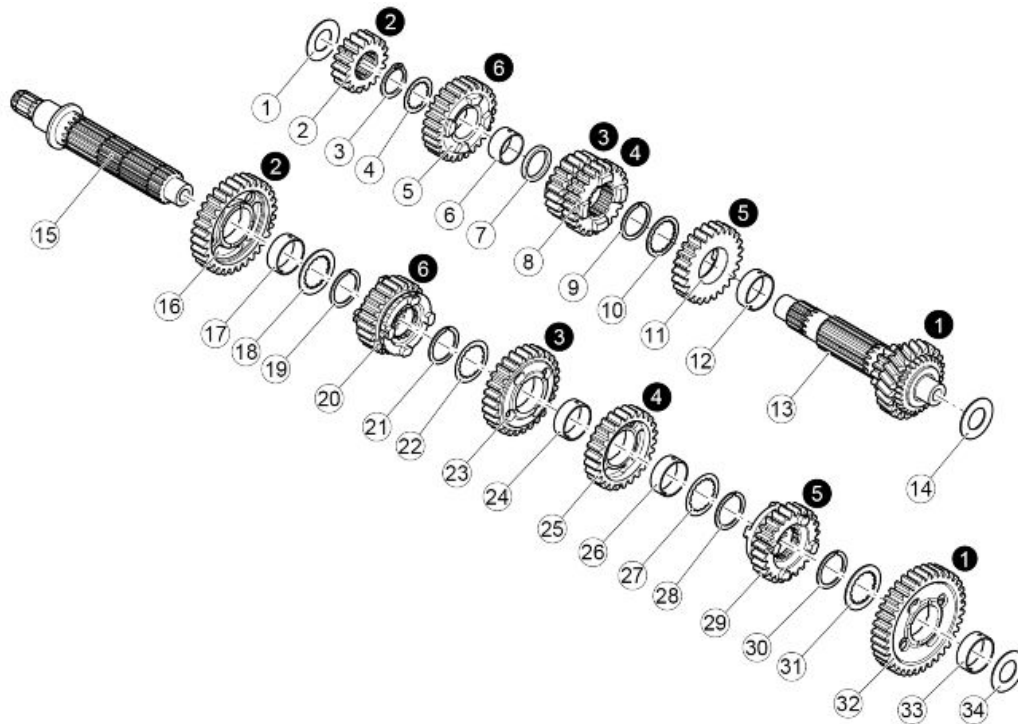

key:

1. Thrust washer
2. 2nd speed gear on main shaft
3. Circlip
4. Thrust washer
5. 6th speed gear on main shaft
6. Floating bushing
7. Main shaft thrust washer
8. 3rd and 4th speed sliding gear on main shaft
9. Circlip for the shaft
10. Thrust washer
11. 5th speed gear on main shaft
12. Floating bushing
13. Main shaft with PI
14. Thrust washer
15. Transmission shaft
16. 2nd speed gear on transmission shaft

17. Floating bushing
18. Thrust washer
19. Circlip for the shaft
20. 6th speed gear on transmission shaft
21. Circlip for the shaft
22. Thrust washer
23. 3rd speed gear on transmission shaft
24. Floating bushing
25. 4th speed gear on transmission shaft
26. Floating bushing
27. Thrust washer
28. Circlip for the shaft
29. 5th speed gear on transmission shaft
30. Circlip for the shaft
31. Thrust washer
32. 1st speed gear on transmission shaft
33. Floating bushing
34. Thrust washer

Gearbox

Removing the gearbox

- Remove the 5 screws (1) fixing the gearbox to the engine crankcase



- Remove the fixing screw (2) of the gearbox, placed from the engine crankcase side



- Remove the complete gearbox screw



Gearbox shafts

Disassembling the gearbox

- Remove the 12 fixing screws of the gearbox, engine side.

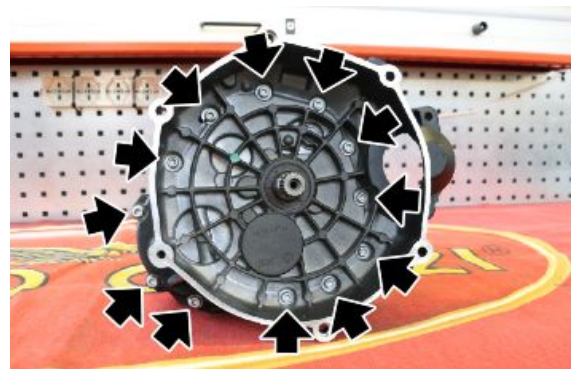

- Remove the fastening screw of the gearbox, cardan side.



- Remove the external body (1), the thrust bearing (2) and two related sliding washers (3) and the external body (4).

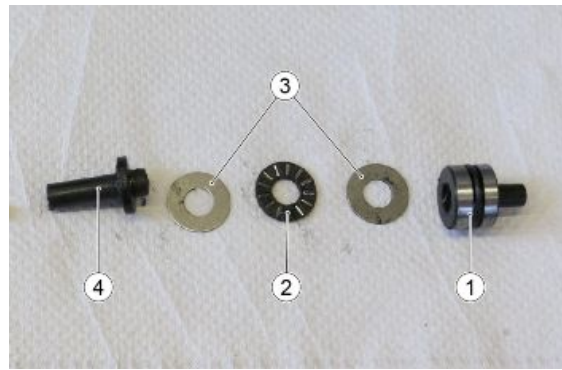

- Remove the pusher plate



- Remove the gearbox cover with a few mallet strokes

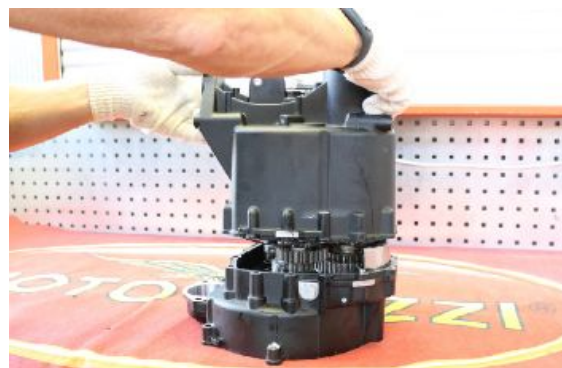

CAUTION

CAREFULLY CLEAN THE THREEBOND FROM THE CONTACT SURFACES BEFORE APPLYING A NEW LAYER OF THREEBOND 1207B DURING THE REASSEMBLY OF THE GEARBOX.

- Having removed all internal components, to remove the bearings fitted in the gearbox crank-cases, the safety washers/plate must be removed first.

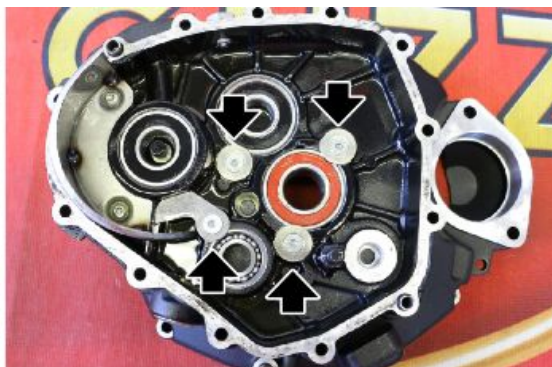

- The bearings from the gearbox crankcases can be removed using generic extractors.



- Heat the primary shaft bearing area on the base of the gearbox crankcase and the secondary shaft area on the gearbox crankcase cover very well with a hair dryer. It will then be possible to remove the bearings by knocking the crankcasings on a surface. If necessary, use a dummy ball bearing extractor.



- If necessary, remove the screws securing the bulkheads located in the crankcase to be able to extract them.



Removing the primary shaft

CAUTION

FIT NEW CIRCLIPS WHEN REASSEMBLING

- Remove the gear selector shaft, the desmodromic shaft and the forks with shaft
- Remove the complete gear unit



To dismantle the main shaft, proceed as follows:

- Remove the shim washer (1)



- Remove the gear of the 2nd gear (2)



- Using the appropriate jaws, lock the primary shaft in a vice and remove the circlip (3)



- Remove the spacer (4)

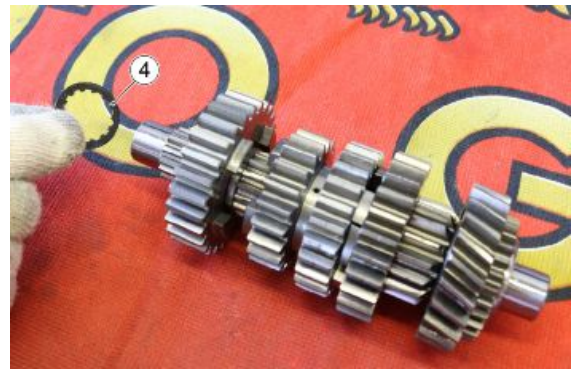

- Remove the gear of the 6th gear (5)



- Remove the bushing (6)



- Remove the spacer (7)



- Remove the gear of the 3-4th gear (8)



- Using the appropriate jaws, lock the primary shaft in a vice and remove the circlip (9)

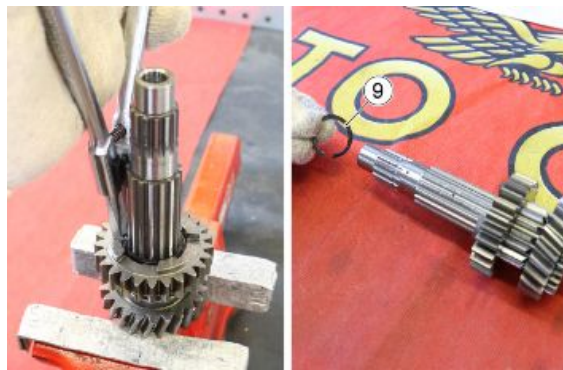

- Remove the spacer (10)

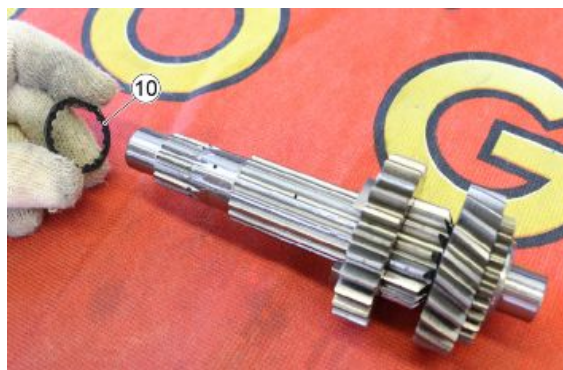

- Remove the gear of the 5th gear (11)



- Remove the bushing (12)



- Remove the washer (13) from the main shaft (14)



Removing the secondary shaft

CAUTION

FIT NEW CIRCLIPS WHEN REASSEMBLING

Disassemble the secondary shaft as follows:

- Remove the shim washer (1)



- Remove the gear of the first gear (2)

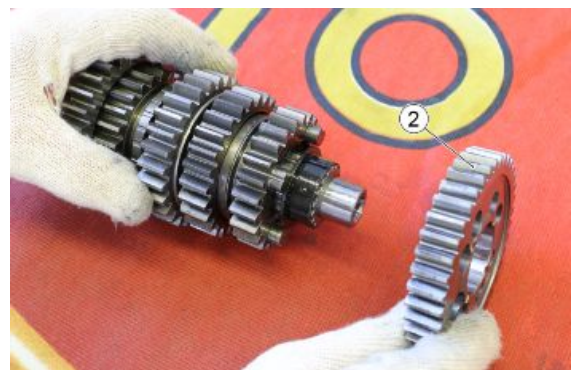

- Remove the bushing (3)



- Remove the shim washer (4)



- Remove the seeger ring (5)



- Remove the gear of the 5th gear (6)



- Remove the seeger ring (7)



- Remove the shim washer (8)



- Remove the gear of the 4th gear (9)



- Remove the bushing (10)

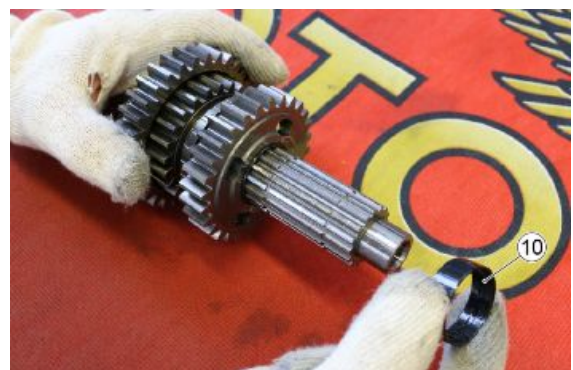

- Remove the gear of the 3rd gear (11)



- Remove the bushing (12)



- Remove the shim washer (13)



- Remove the seeger ring (14)



- Remove the gear of the 6th gear (15)



- Remove the seeger ring (16)

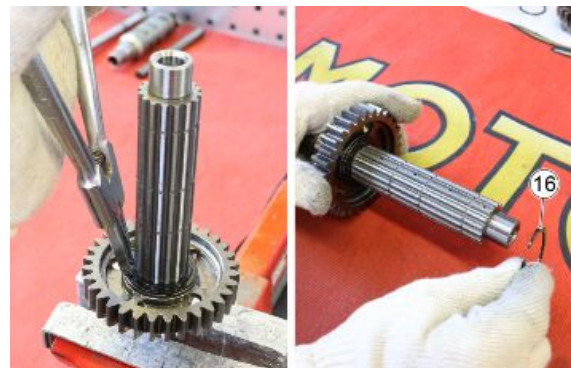

- Remove the shim washer (17)



- Remove the gear of the 2nd gear (18)



- Remove the bushing (19)



Desmodromic demounting

- Remove the fork carrier shaft (1).



- Remove the desmodromic shaft (2).



- The forks are marked with a serial number that indicated the correct positioning.
- Remove the upper fork No.1 (3)



- Remove the lower fork No.3 (4)



- Remove the primary and secondary shaft, as well as the intermediate fork No. 2



Disassembling the clutch shaft

- To remove the clutch shaft it is necessary to remove first all gearbox components (the input shaft, the secondary shaft, fork travel shaft and the forks, gearbox selector).
- At this point, the clutch shaft can be removed with a few mallet taps, paying attention to retrieve the shimming washer.
- Remove the oil seal from the clutch shaft



WARNING

IN CASE OF OIL SEAL REPLACEMENT, WHEN REFITTING USE THE SUITABLE PUNCH UNTIL IT REACHES THE END

Specific tooling

020976Y Clutch control dust guard mounting punch



- Remove the oil seal

CAUTION

IN CASE OF OIL SEAL REPLACEMENT, USE THE SUITABLE PUNCH UNTIL IT REACHES THE CRANKCASE

Specific tooling

021020Y Clutch housing oil seal mounting punch



CLUTCH SHAFT DISASSEMBLY

- Using a hydraulic press and a generic support, remove the seeger ring (1) for the inspection / check of the concentric springs of the clutch shaft.

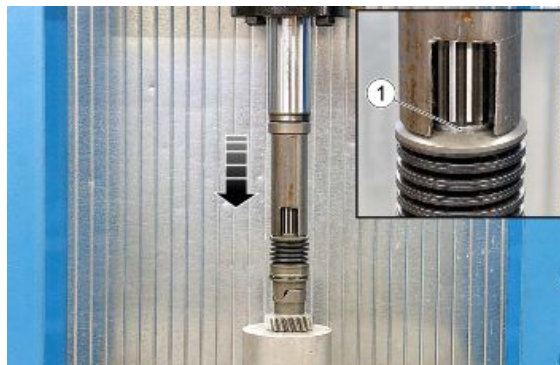

- Measure the free spring pack (A) and, following this measurement, use the corresponding number of "support washers" (B) identified in the table below.

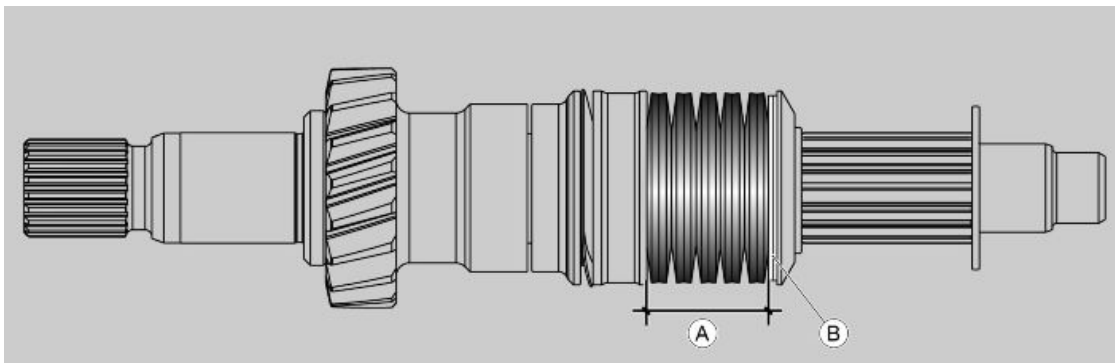

SUPPORT WASHERS SELECTION

(A) 10 SPRING WASHERS PACK FREE THICKNESS	(B) SUPPORT WASHERS QUANTITY
26.000-26.999 mm	4
27.000-27.999 mm	3
28.000-28.999 mm	2
29.000-30.000 mm	1

Controllo alberi

Check transmission gears for signs of pitting and wear and replace damaged gears if necessary.
 Check the gear fitting teeth for cracks, damage and wear and replace those damaged if necessary.
 Check the transmission gears movement and, if it is not regular, replace the damaged part.

WEAR LIMITS

Specification	Desc./Quantity
Maximum wear limit for the selection gear grooves	22.78 mm (0.896 in) with rollers diam. 3.5 mm (0.14 in)
Minimum wear limit of the cardan shaft side secondary shaft seats	23.294 mm (0.9171 in) with rollers diam. 3.0 mm (0.12 in)
Minimum wear limit of the clutch side primary and secondary shaft seats	24.112 mm (0.9493 in) with rollers diam. 2.0 mm (0.08 in)

Checking the clutch shaft

Check for pitting, wear, cracks or damage, signs of deterioration on the teeth of the primary drive gear and replace the gear if necessary



WEAR LIMITS

Specification	Desc./Quantity
(1) Minimum wear limit of the rotation point on the gearbox cover bearing	19.975 mm (0.7864 in)
(2) Minimum wear limit of the rotation point on the gearbox cover base	24.987 mm (0.9837 in)

Checking the desmodromic drum

Check the desmodromic drum for damage, scratches and wear and replace the assembly if required.

Checking the forks

Check that the forks have the work surface well smooth and not worn, so to lose its quenching characteristics and that the nibs that are working in the drum grooves are not too worn, otherwise replace the forks.

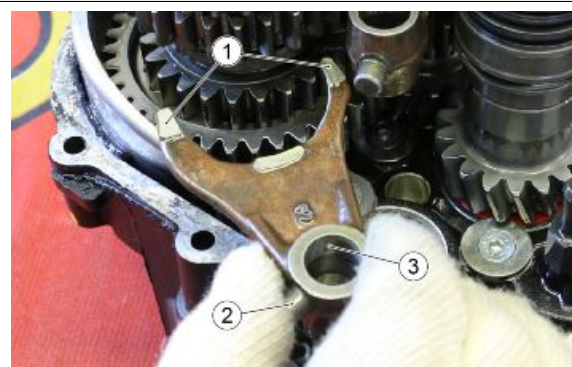

WEAR LIMITS

Specification	Desc./Quantity
(1) Minimum thickness of the tines	4.75 mm (0.19 in)
(2) Guide pins minimum diameter	8 mm (0.31 in)
(3) Sliding hole minimum diameter	14 mm (0.55 in)

Assembling the gearbox

- In case of secondary oil seal replacement of the cardan on the gearbox cover, use the special punch until it stops.

Specific tooling

020978Y Cardan secondary oil seal mounting punch



- Use commercial punches to insert the bearings on the gearbox crankcases.

- A special punch must be used to insert the bearings on the seats of the primary/secondary shaft with lubrication duct.

Specific tooling

GU19926500 Punch for transmission case bearing external ring



- After installing the bearings on the gearbox crankcasings, position the bulkheads and the safety washers/plates, and tightening them with the appropriate screws to the prescribed torque.

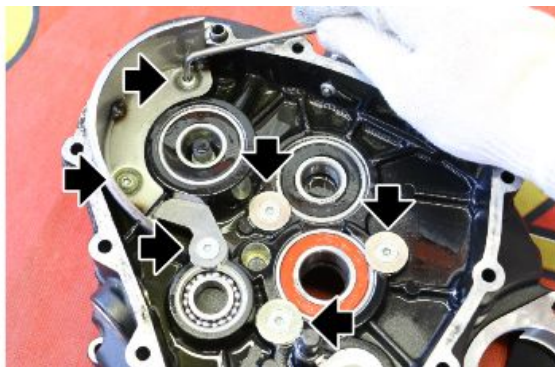
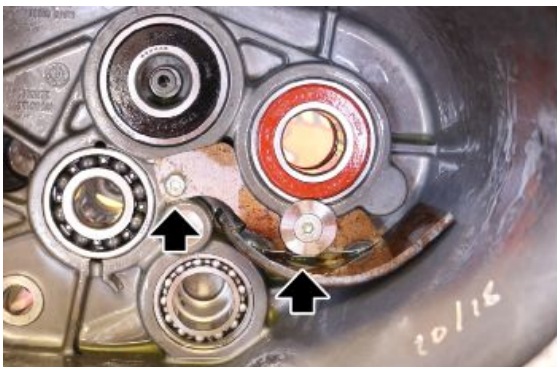

- After inserting all the internal components, apply a layer of threebond 1207B on the junction surface of the two crankcasings.



- Position the gearbox cover and manually tighten the gearbox fixing screw on the cardan side.



- Insert the 12 fixing screws of the gearbox, engine side and then tighten them to the prescribed torque, including the screw opposite the cardan side previously tightened manually.

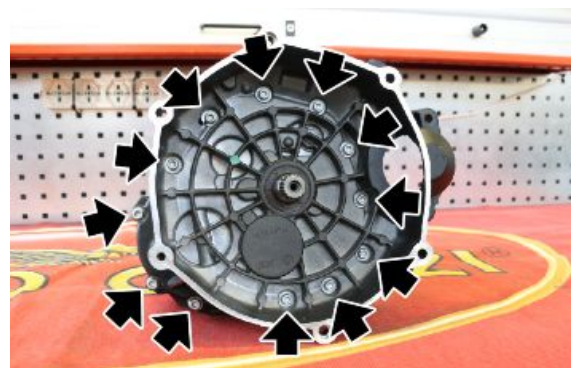

- After inserting the two half-cones (1) on the thrust plate (2), insert it on the clutch shaft working from the cardan side and paying attention to the orientation, as the machining must push on the cap once the reassembling of the gearbox on the engine is complete.

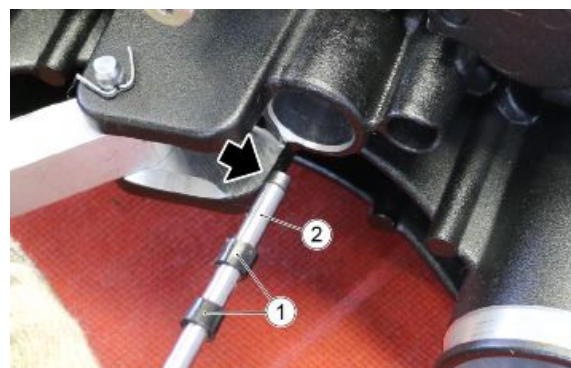

- Insert the intermediate body (3), the thrust bearing (4) and two related sliding washers (5) and the external body (6).

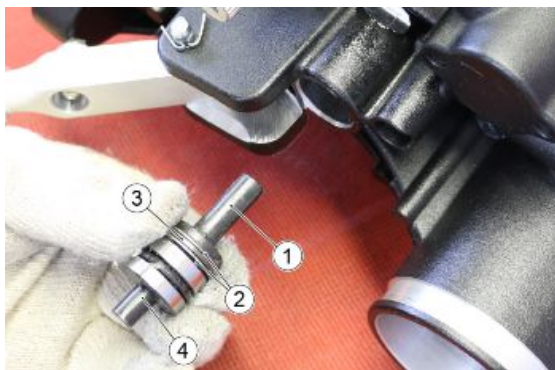

Gear selector

Removing the gear selector

- Remove the desmodromic shaft first and then the complete gear selector shaft (1).



- Remove the spring from the index lever (2)



- Remove the washer (3)



- Remove the seeger ring (4)



- Remove the seeger ring (5)



- Remove the washer (6)



- Remove the bushing (7)

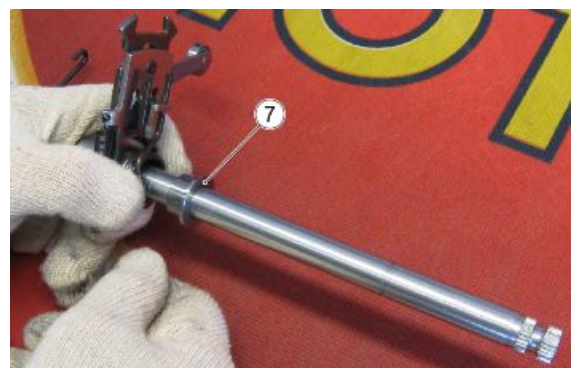

- Remove the selector spring (8)

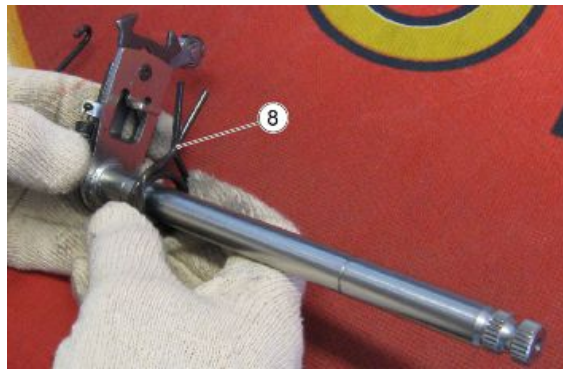

- Remove the ring (9)



- Remove the bushing (10)

WARNING

DURING REFITTING, PAY ATTENTION TO THE CORRECT POSITIONING OF THE BUSHING, AS THE SIDES ARE NOT SYMMETRICAL



- Remove the index lever (11)

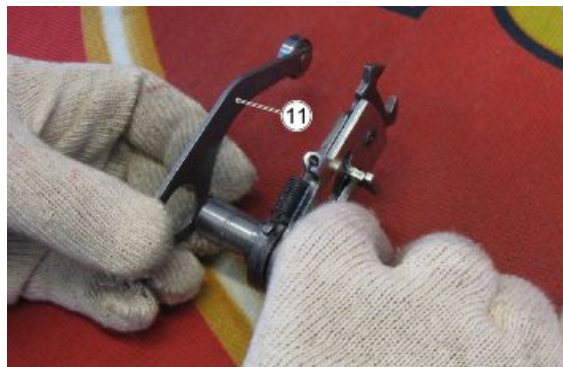

- Remove the selector return spring (13)

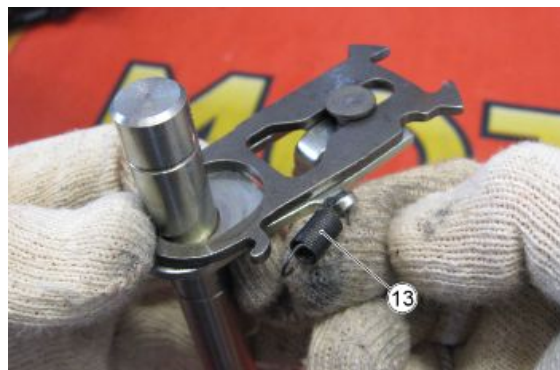

Generatore

Rimozione sensore giri

NOTE

PROCEDURE VALID ONLY FOR E4 VEHICLES

- Undo and remove the fixing screw of the sensor



- Remove the timing system cover sensor



Generator removal

ALTERNATOR COVER REMOVAL

- Remove the alternator cover fixing screws

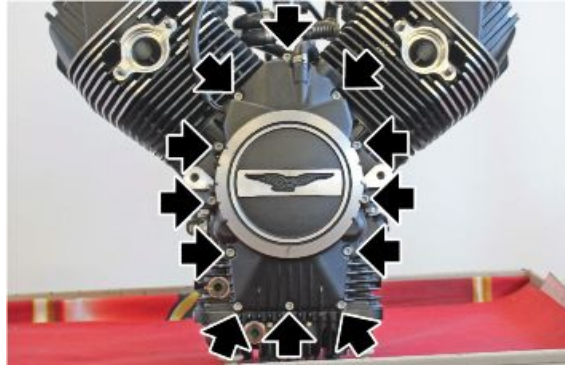

- Remove the alternator cover.



- Remove the gasket.



ROTOR REMOVAL

- From the clutch side, partially unscrew the two fixing screws of the clutch plate, as indicated, to allow the correct positioning of the specific clutch lock tool.

Specific tooling

021001Y Clutch retainer tool

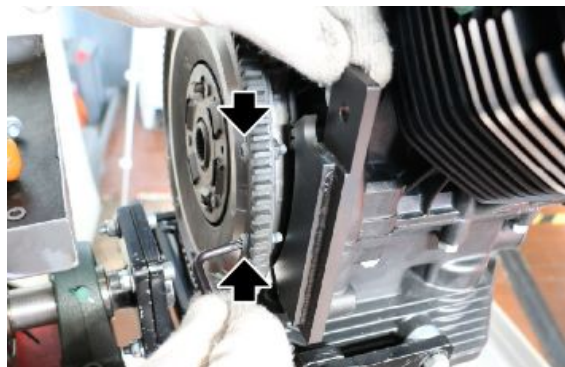

- Using one of the fixing screws of the gearbox assembly, secure the specific tool.

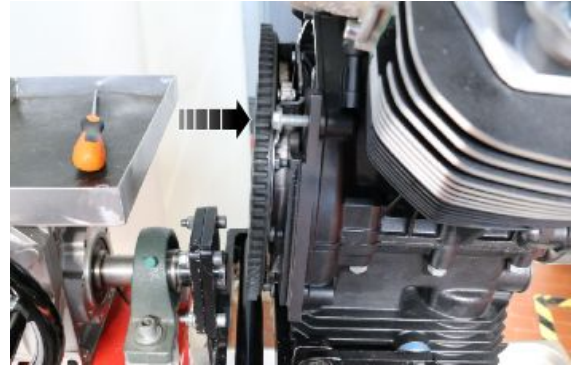

- Place the tool (1) on the rotor, tighten the threaded pin (2) of the tool and proceed with the rotor removal

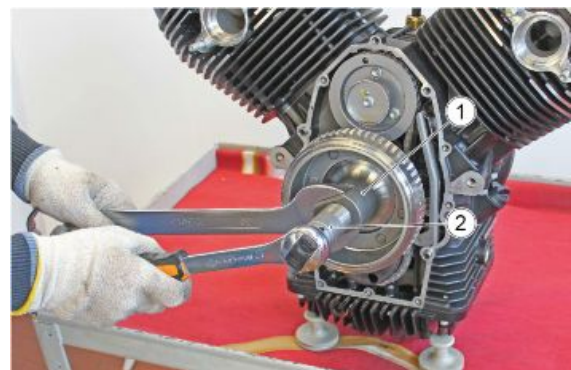

Specific tooling

020713Y Flywheel extractor

NOTE

PROCEDURE VALID ONLY FOR E4 VEHICLES

OIL SEAL REMOVAL

- Operating in the alternator cover, to remove the oil seal of engine oil circuit system sealing, the seeger must be removed



- Remove the washer



- Extract the oil seal



NOTE

PROCEDURE VALID ONLY FOR E4 VEHICLES

STATOR REMOVAL

- Remove the stator wiring harness lock plate



- Removing the three stator fixing screws makes it possible to disconnect it

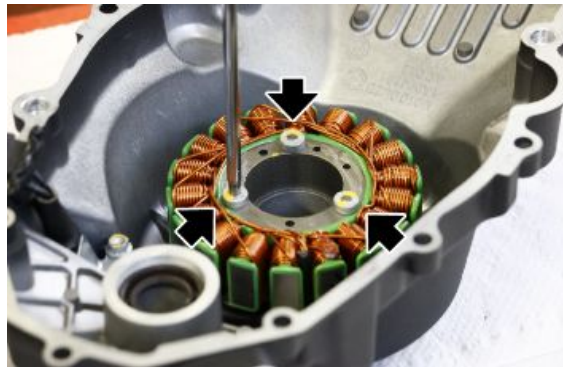

NOTE

PROCEDURE VALID ONLY FOR E5 VEHICLES

STATOR REMOVAL

- Remove the two pick-up plate fixing screws



- Remove the three fixing screws fastening the stator to the timing system cover
- At this point, the stator can be removed from the cover, together with the wiring harness and the pick-up

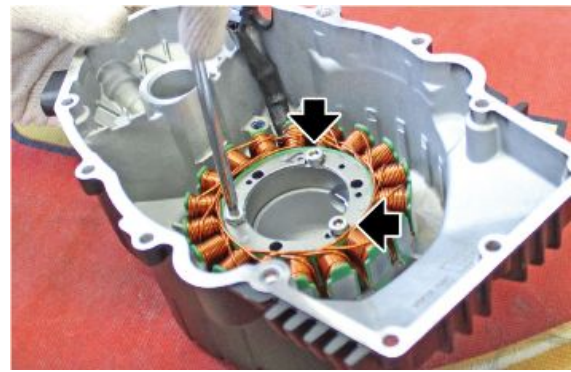

Generator Installation

NOTE

PROCEDURE VALID ONLY FOR E4 VEHICLES

- During refitting of the flywheel cover it is necessary to apply a great amount of threebond on the cable grommet of the stator before placing it in its seat



- Check that plentiful threebond leaks out and covers all space between the seat on the cover and the cable grommet. Apply another layer of threebond over the cable grommet.



- Refit a new gasket.



NOTE

PROCEDURE VALID ONLY FOR E5 VEHICLES

- During refitting of the flywheel cover it is necessary to apply a great amount of threebond on the cable grommet of the stator before placing it in its seat

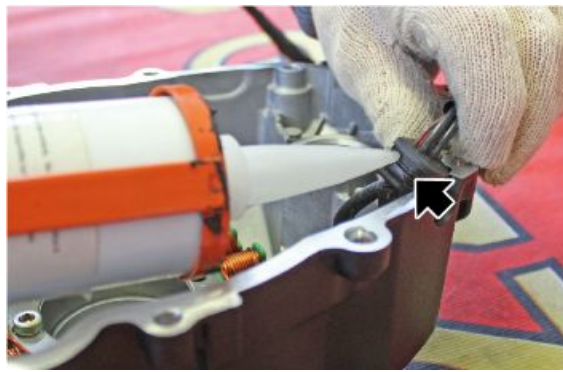

- Check that plentiful threebond leaks out and covers all space between the seat on the cover and the cable grommet. Apply another layer of threebond over the cable grommet.



- Refit a new gasket.

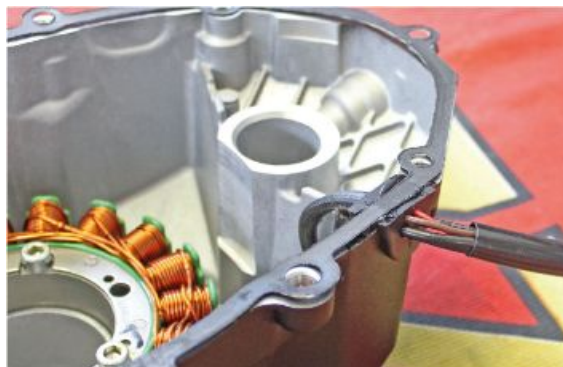

STONE WHEEL CALIBRATION PROCEDURE

NOTE

PROCEDURE VALID ONLY FOR E5 VEHICLES

CAUTION

To comply with the strict "MISFIRE" monitoring requirements of by the EURO 5 regulations, a new tone wheel and a new integrated Pick-Up have been included in the stator's wiring harness. When the "MISFIRE" monitoring does not return optimal results and/or if the tone wheel calibration procedure is not performed, the MIL indicator light will start flashing. (the ECU will show the P1309 error)

All motorcycles are delivered with the calibration procedure already performed, but in case of replacing the: ENGINE ECU, MAGNET FLYWHEEL, PICK UP, the calibration procedure described below must be repeated.

- Use P.A.D.S. to "RESET THE TONE WHEEL VALUES". This item can be selected from the following path: "Adjustments" - "ECU EEPROM reset"
- Bring the engine to a temperature of 80°
- With the gearbox in neutral and the vehicle at a standstill, accelerate three times over 6500 rpm
- Switch off the panel and wait for at least one minute (Power Latch)



CAUTION

The procedure is successful ONLY if the vehicle's speed stays a 0 Km/h

Starter motor

Removing the starter motor

- Remove the starter motor fixing screws (1)



- Remove the supporting clamp of the protection (2) and the starter motor (3)

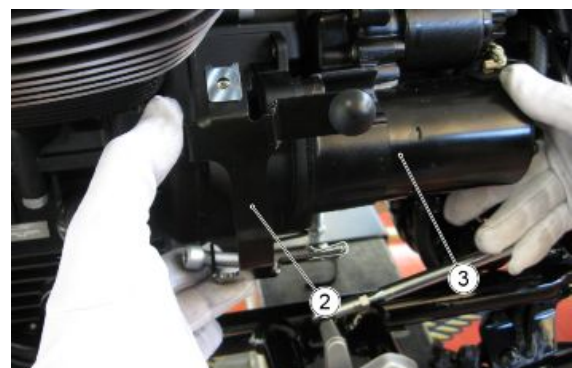

Clutch side

Disassembling the clutch

- Remove the clutch cover.
- Partially unscrew the two fixing screws of the clutch plate, as indicated, to allow the correct positioning of the specific clutch lock tool.

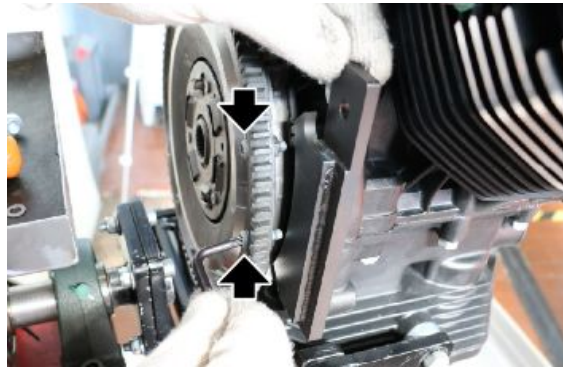

Specific tooling

021001Y Clutch retainer tool

- Using one of the fixing screws of the gearbox assembly, secure the specific tool.

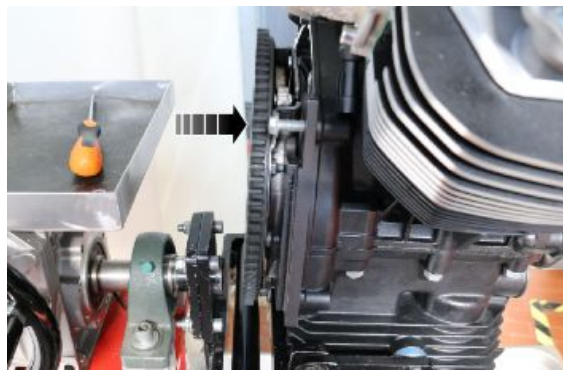

- Remove the 6 fixing screws of the clutch plate complete with starter sprocket

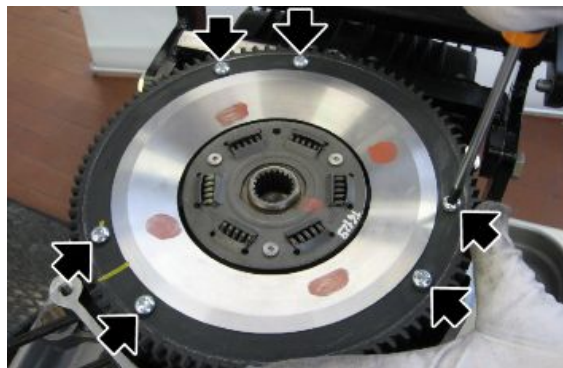

- Remove the clutch plate complete with starter sprocket



- Remove the clutch disc.



- Remove the retainer ring



- Remove the thrust plate



- Remove the 6 fixing screws of the locking plate



- Remove the reinforcement flange of the clutch thrust plate



- Remove the clutch lock complete



- Remove the spacer plate.



Checking the clutch plates

Clutch disc

Make sure that the clutch plate is not scratched or badly worn. Check the flexible springs and the thickness of the clutch disc

Characteristic

Minimum disc wear thickness

0.9 mm (0.04 in)

Starting sprocket

Check that the supporting surface with the driven plate is perfectly smooth and even.

Also check that the tothing where the starter motor pinion works is not chipped or scratched; otherwise, replace it.



Assembling the clutch

- Insert the spacer plate on the crankshaft.



- Insert the complete clutch lock.



- Place the reinforcement flange of the clutch thrust plate, aligning the holes with the ones of the clutch base



- Insert the 6 fastening screws complete with washers and tighten to the prescribed torque



- Insert the thrust plate cap



- Lock the thrust plate using the special lock ring

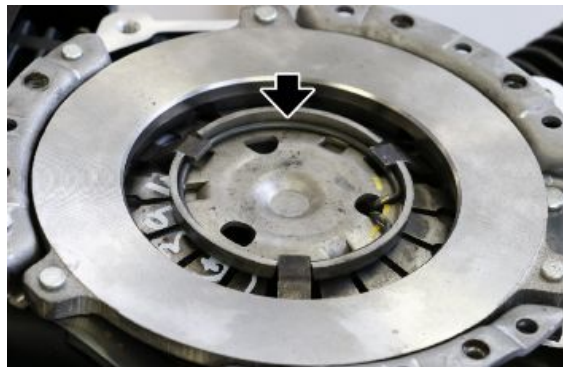

- Place the clutch plate



- Place the starter sprocket and screw the fixing screws by hand



- Using the special tool for the centring of the clutch plate

Specific tooling

021002Y Clutch centring



- Insert the six fastening screws at the recommended torque.



Bushing selection

CRANKSHAFT - CRANKCASE BUSHINGS

The crankcase class is stamped in the following locations:

- Alternator side, on the upper crankcase in correspondence with the crankshaft hole, on the left.
- Clutch side, on the upper crankcase in correspondence with the crankshaft hole, on the right.

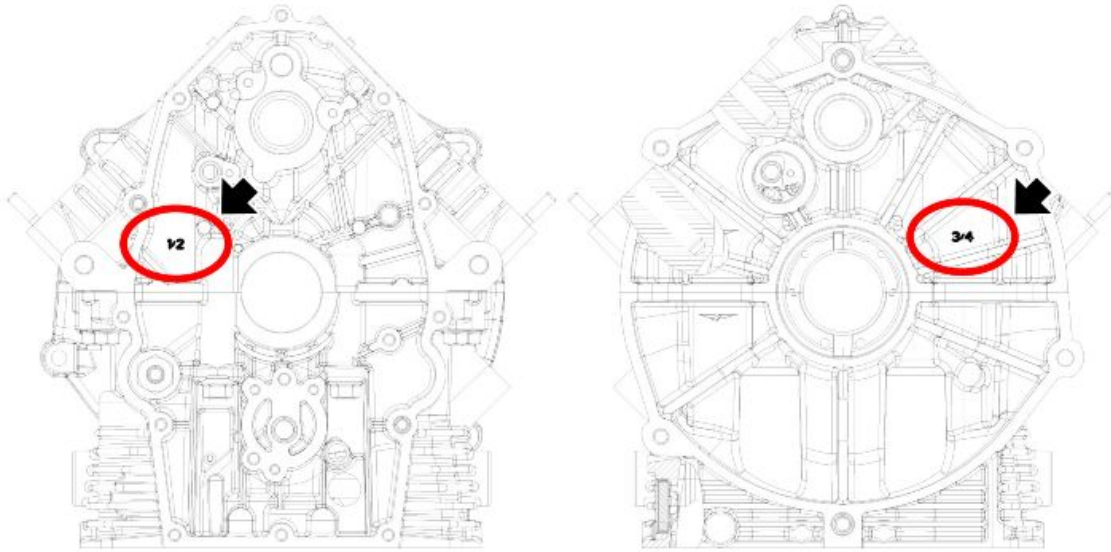

CRANKCASE HOLE DIAMETER

Specification	Desc./Quantity
Class 1	Bushing seat diameter: 43.657-43.663 mm (1.7188-1.7190 in)
Class 2	Bushing seat diameter: 43.664-43.670 mm (1.7191-1.7193 in)
Class 3	Bushing seat diameter: 47.130-47.136 mm (1.8555-1.8557 in)
Class 4	Bushing seat diameter: 47.137-47.142 mm (1.8558-1.8560 in)

Four different crankcase classes are available:

- (1-2) according to diameter of hole in half crankcase shells on alternator side.
- (3-4) according to diameter of hole in half crankcase shells on clutch side.

CRANKSHAFT

Based on the development and improvement process, the crankshaft categories can be stamped on the crankshaft counterweights (figure A)

(A)

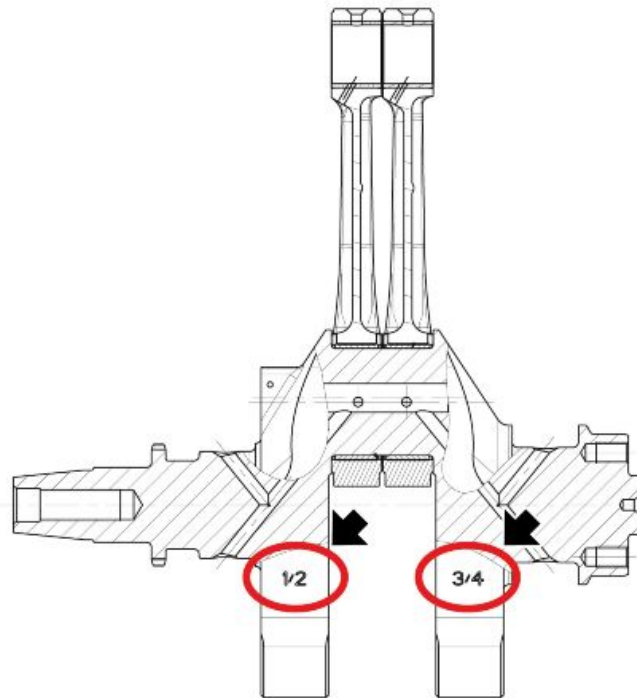

Or alternatively, laterally on the counterweights of the crankshaft (figure B)

(B)

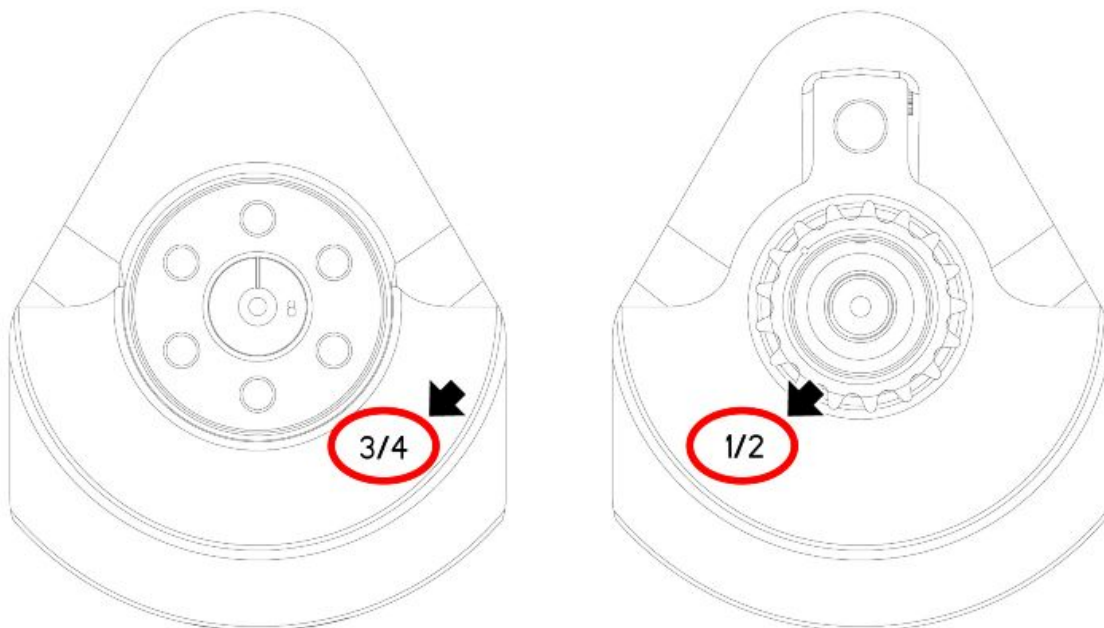

MAIN CRANKSHAFT JOURNAL DIAMETER

Specification	Desc./Quantity
Class 1	Diameter: 40.004-40.012 mm (1.5750-1.5753 in)
Class 2	Diameter: 40.013-40.020 mm (1.5753-1.5756 in)
Class 3	Diameter: 43.007-43.015 mm (1.6932-1.6935 in)
Class 4	Diameter: 43.016-43.023 mm (1.6935-1.6937 in)

Four different crankshaft classes are available:

- (1-2) according to main journal diameter on alternator side.
- (3-4) according to main journal diameter on clutch side.

SELECTING CRANKSHAFT - CRANKCASE BUSHING CLASSES

Crankcase class	Class 1 crankshaft	Class 2 crankshaft	Class 3 crankshaft	Class 4 crankshaft
Class 1	green-green	yellow-yellow	-	-
Class 2	black-black	green-green	-	-
Class 3	-	-	green-green	yellow-yellow
Class 4	-	-	black-black	green-green

Head and timing

Removing the head cover

NOTE

THE OPERATIONS FOR THE REMOVAL OF THE HEAD COVER ARE THE SAME FOR BOTH SIDES

- Remove the spark plug cover
- Disconnect the spark plug tube
- Remove the blow-by pipe
- Undo the three fixing screws of the head cover and remove the gasket

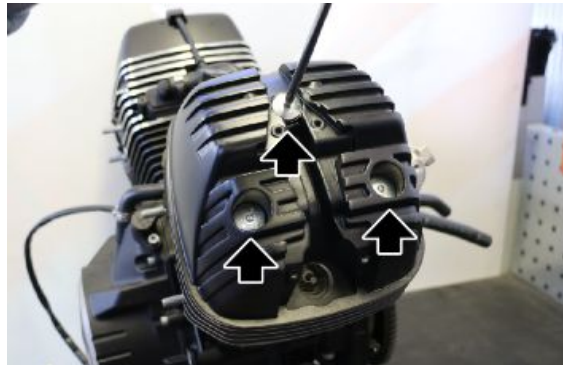

- Remove the head cover together with the gaskets



- Remove the gasket from the head cover



- Check that the mating faces that contact the heads are not damaged or blistered

Removing the cylinder head

NOTE

THE HEAD REMOVAL OPERATIONS REFER TO ONE HEAD BUT APPLY TO BOTH

- Remove the head cover
- Unscrew the spark plug



- Bring the piston of the left cylinder to top dead centre
- Check that the punching of the crankshaft pinion (1) is aligned with the punching on the timing system sprocket (2). The punching on the timing system sprocket can be viewed through the hole of the chain guide cap

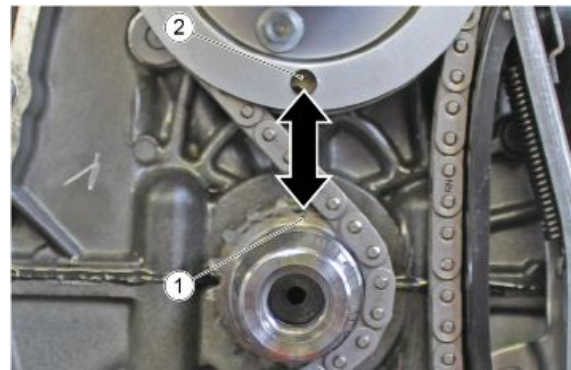

NOTE

PROCEDURE VALID ONLY FOR E5 VEHICLES

- Remove the fastening screw of the rocker pin retainer fork

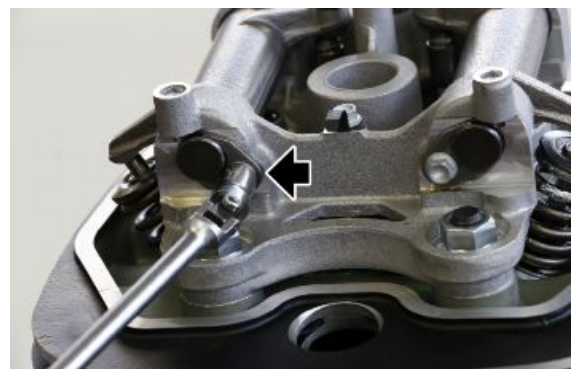

- Remove the rocker pin retainer fork

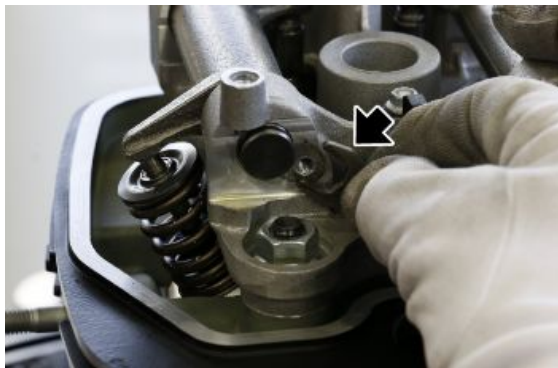

- Remove the rocker pin



CAUTION



THE INTAKE VALVE IS CHARACTERIZED BY THE PRESENCE OF A CALIBRATED PAD, THEREFORE PAY PARTICULAR ATTENTION TO RECOVER IT DURING DISASSEMBLY.

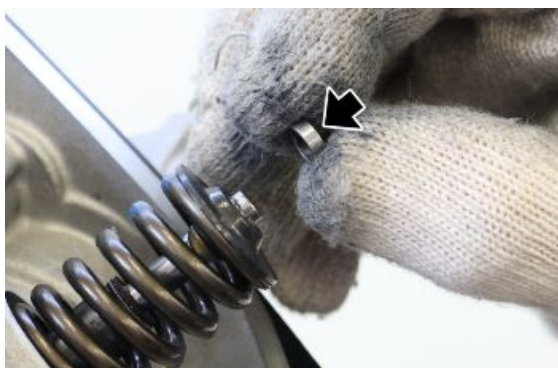

- Remove the rocker, being careful to recover the Belleville spring

NOTE

REPEAT THE SAME PROCEDURE TO REMOVE THE OTHER ROCKER

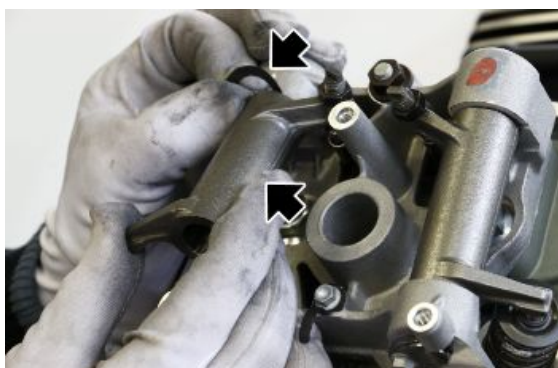

- Remove the rocker rods

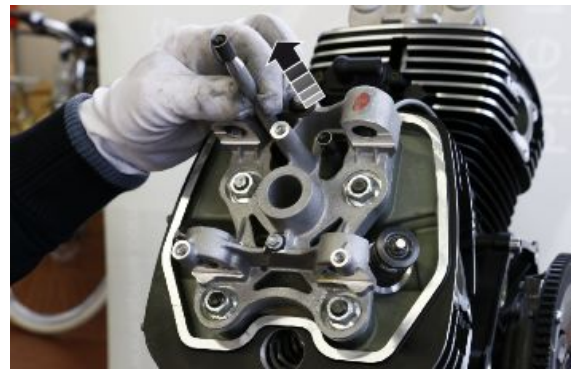

- Remove the nut with relevant washer of the cylinder to the crankcase



- Unscrew and remove the compensation nut of the cam tower



- Undo and remove the fastening nuts of the cam tower

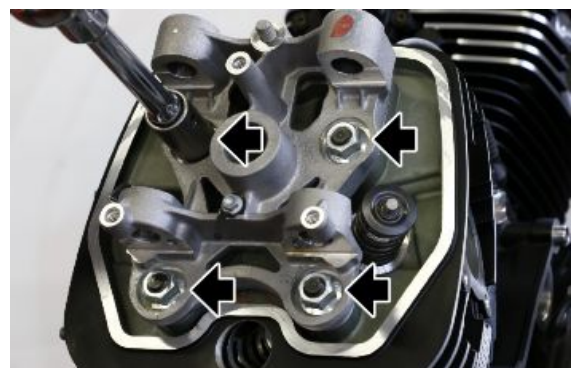

- Remove the cam tower



- Remove the three rubber O-Rings

CAUTION



PAY SPECIAL ATTENTION THAT THE O-RINGS DO NOT ACCIDENTALLY FALL INTO THE PROCESSING HOLES OF THE ROCKERS RODS

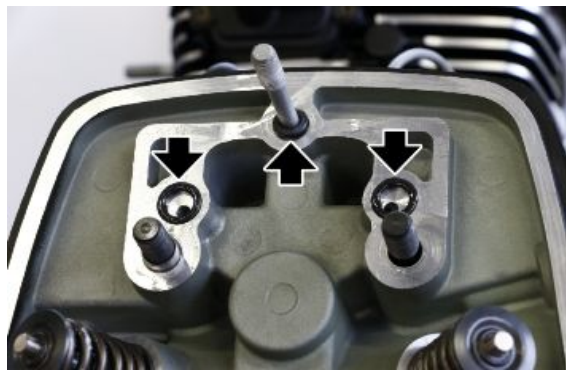

- Remove the complete head



- Remove the cylinder head gasket



- Undo and remove the engine oil pressure sensor

NOTE

ONLY FOR E4 VEHICLES



- Undo and remove the secondary air valve cover



- Remove the secondary air valve
- check and if necessary replace the external rubber gasket



- Remove the internal filter paying attention to the direction during refitting



Cylinder head

Removing the valves

- Place the special tool on the upper cap of the valve to be removed and at the centre of the head of the valve.

Specific tooling

020382Y Tool to extract valve cotters



- Close the tool to compress the spring and remove the two half-cones from the upper cap

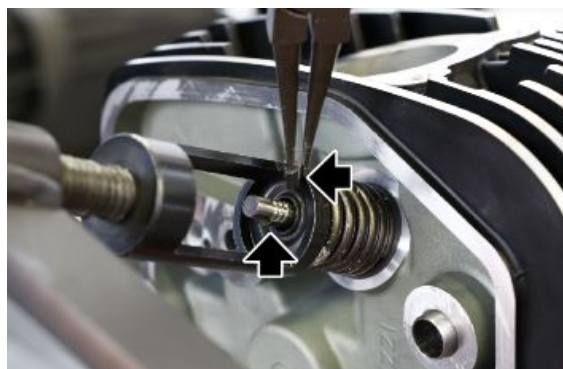

- Unscrew the tool and remove it from the head
- Remove the upper cap

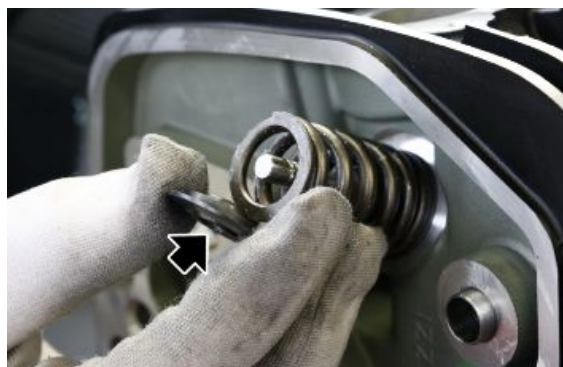

- Remove the spring and replace it if it is out of the wear limit.



- Remove the valve from the head



- Remove the gasket of the valve guide



VALVE GUIDES MUST BE REPLACED WHEN THEY ARE WORN TO THE POINT THAT REPLACING THE VALVE ALONE IS NOT ENOUGH TO ELIMINATE CLEARANCE BETWEEN VALVE STEM AND VALVE GUIDE BORE.



- Remove the lower cap of the spring



Checking the rocker arms

- Check that the bolt surface that contacts the rockers is not exceedingly worn.
- Check the rocker to valve and rocker to rod contact surfaces.



Valve check

If the below shown values are out of the limits of the component wear, replace it

Intake valves:

Characteristic**Coupling clearance between valve and guide (WEAR LIMIT)**

0.05 mm (0.0020 in)

Valve stem distortion (MEASURED ON 45°)

0.03 mm (0.0012 in)

Valve stem diameter (MINIMUM WEAR VALUE)

5.95 mm (0.2342 in)

Valve head eccentricity (MAXIMUM ALLOWED VALUE)

0.05 mm (0.0020 in)

Outlet valves:

Characteristic**Coupling clearance between valve and guide (WEAR LIMIT)**

0.06 mm (0.0024 in)

Valve stem distortion (MEASURED ON 45°)

0.03 mm (0.0012 in)

Valve stem diameter (MINIMUM WEAR VALUE)

5.92 mm (0.2331 in)

Valve head eccentricity (MAXIMUM ALLOWED VALUE)

0.05 mm (0.0020 in)

Inspecting the springs and half-cones

- Check that the upper spring caps and the half-cones show no signs of abnormal wear.
- Check the unloaded spring length.

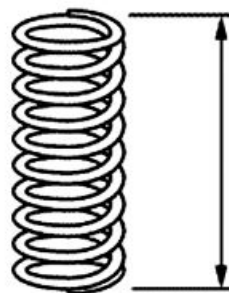
**Characteristic****Spring free length (WEAR LIMIT)**

45.9 mm (1.81 in)

Adjusting valve clearance

- Bring the piston of the left cylinder to top dead centre making sure that the reference mark on the crankshaft gear and on the timing system shaft are aligned.

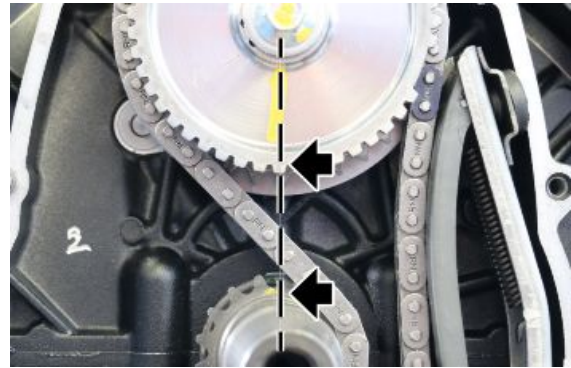

NOTE
PROCEDURE VALID ONLY FOR E4 VEHICLES

- Bring the piston of the left cylinder to top dead centre
- Check that the punching of the crankshaft pinion (1) is aligned with the punching on the timing system sprocket (2). The punching on the timing system sprocket can be viewed through the hole of the chain guide cap

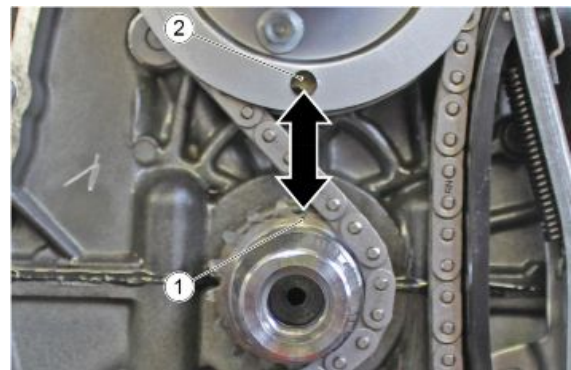

NOTE
PROCEDURE VALID ONLY FOR E5 VEHICLES

- Use a feeler gauge to check that the clearance between the valve and the set screw corresponds with the indicated values. The corresponding intake and outlet valve clearances are different than what is indicated below, proceed with adjusting them.



Characteristic

Intake valve clearance

0.10 mm (0.0039 in)

Exhaust valve clearance

0.15 mm (0.0059 in)

- Loosen the lock nut, adjust the clearance by acting on the adjuster until reaching the prescribed values
- Tighten the lock nut



Timing

Rimozione ruota fonica

NOTE

PROCEDURE VALID ONLY FOR E4 VEHICLES

- Remove the timing system cover.
- Remove the rotor.
- Remove the screw fastening and washer of the tone wheel.

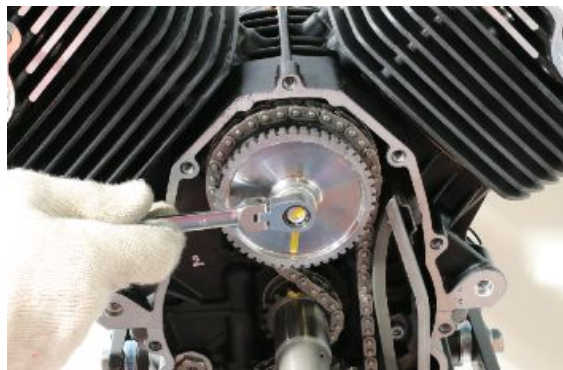

- Remove the tone wheel

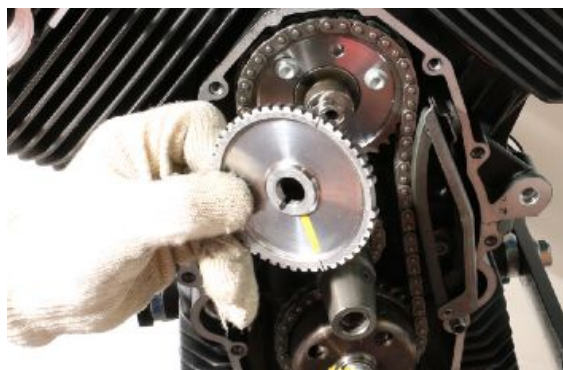

Removing the chain tensioner

- Remove the timing system cover
- Remove the flywheel
- Remove the chain tensioner fixing screw recovering the washer

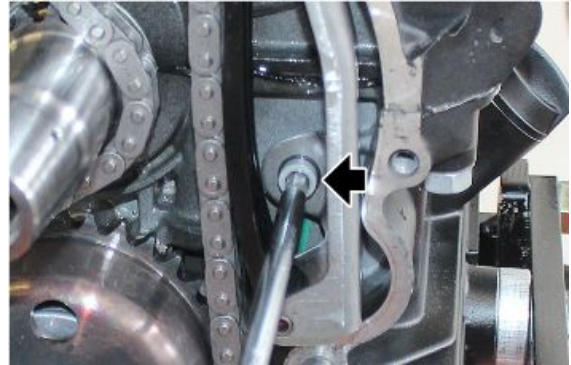

- Remove the chain tensioner



Chain removal

- Remove the timing system cover, the rotor and the tone wheel.
- Remove the three fixing screws of the timing gear.

NOTE
ONLY FOR E4 VEHICLES

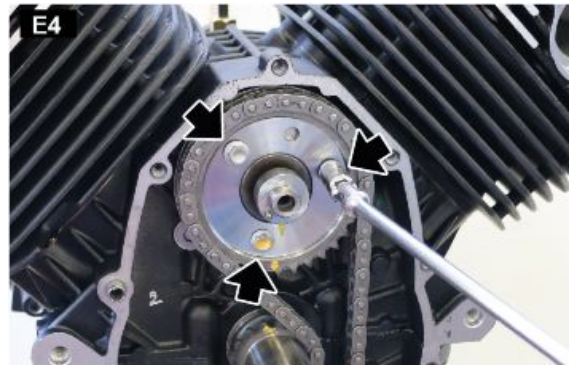

- Remove the timing system cover, the flywheel and the chain tensioner adjuster screw.
- Remove the bulkhead screw.

NOTE
ONLY FOR E5 VEHICLES

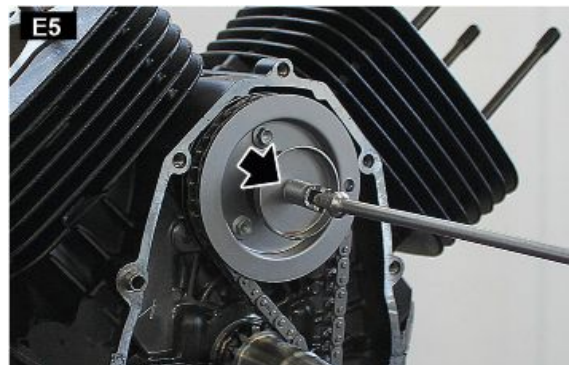

- Remove the 3 fixing screws of the timing system sprocket and retrieve the front chain guide cap.

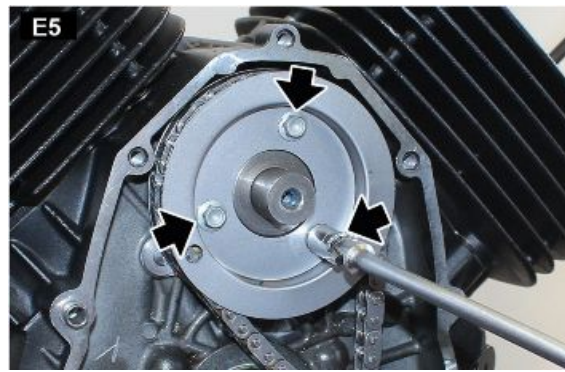
**NOTE**

ONLY FOR E5 VEHICLES

- Remove the fixing screw with relative washer for the oil pump gear.

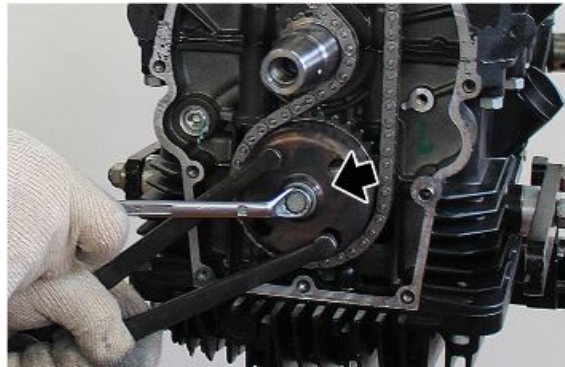

- Remove the timing chain, removing the camshaft gear and the oil pump gear at the same time

NOTE

PAY ATTENTION TO THE CENTRING PIN OF THE OIL PUMP GEAR.



- Retrieve the rear chain guide cap.



Removing the camshaft

NOTE

PROCEDURE VALID ONLY FOR E4 VEHICLES

WARNING

THE BUCKET TAPPETS MUST BE REMOVED IN ORDER TO DISASSEMBLE THE CAMSHAFT.

- Remove the timing system cover, the rotor, the tone wheel, the timing system with gear and the blow-by cap.
- Remove the two fixing screws of the camshaft.

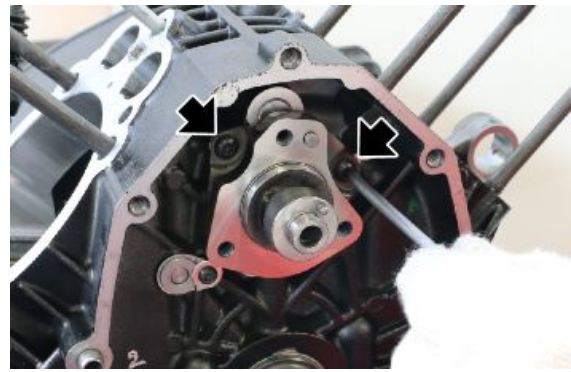

- Remove the camshaft extracting it from the crankcase.



NOTE

PROCEDURE VALID ONLY FOR E5 VEHICLES

- Remove the big ends and the cylinders.
- Remove the bucket tappets from the engine crankcase.



- Remove the timing system cover, the flywheel and the timing system chain.
- Remove the two fixing screws of the camshaft.



- Remove the camshaft extracting it from the crankcase and retrieve the fixing flange.

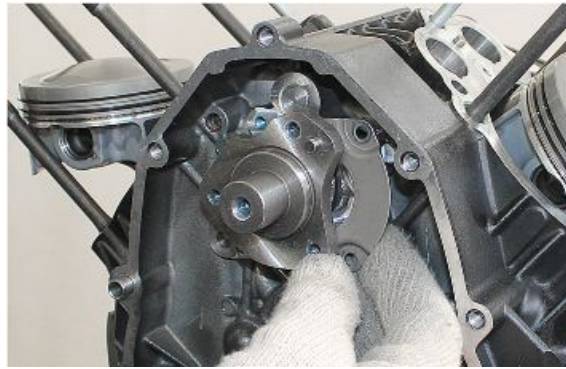

Installing the camshaft

NOTE

PROCEDURE VALID ONLY FOR E4 VEHICLES

- Insert the camshaft into the crankcase.

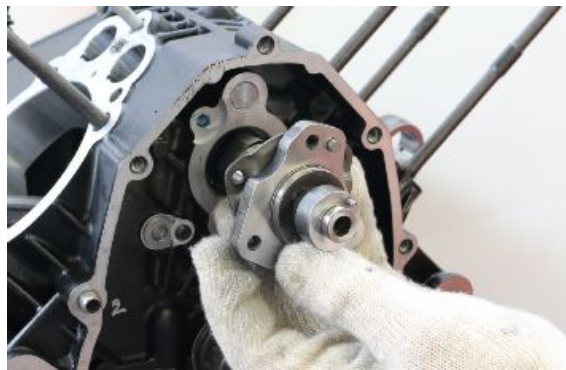

- Place the two fixing screws and tighten them to the prescribed torque.



NOTE

PROCEDURE VALID ONLY FOR E5 VEHICLES

- Insert the camshaft into the crankcase.
- Insert the flange in the specific slot.



- Place the two fixing screws and tighten them to the prescribed torque.

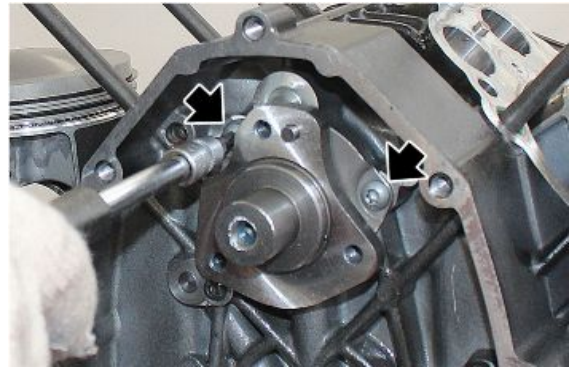

- Place the bucket tappets paying attention to the centring pin. Apply grease ensuring that it does not fall.



Installazione piattello blow-by

- Place the blow-by cap on the camshaft making the holes and the special timing plug match



Installazione catena

- For the installation of the timing chain, it is necessary to carry out the "Timing" procedure, therefore consult the specific chapter.

Installing the phonic wheel

NOTE

PROCEDURE VALID ONLY FOR E4 VEHICLES

- Fit the tone wheel checking the correct positioning on the camshaft, using the centring plug



- Insert the screw complete with washer to fasten the tone wheel and tighten it to the prescribed torque.



Cam timing

Timing

- Bring the piston of the left cylinder to top dead centre making sure that the reference mark on the crankshaft gear is up on the perpendicular axis and that the rocker have clearance



- After having placed the rear chain guide cap, fit the timing system chain, together with the timing system gear and the oil pump gear.



WARNING

PRIOR TO POSITIONING THE TIMING CHAIN WITH GEAR, ALIGN AS MUCH AS POSSIBLE THE MILLING PRESENT ON THE OIL PUMP PIN WITH THE GEAR OF THE PUMP ITSELF, TO ALLOW THE INSERTION OF THE SAFETY PLUG.

CAUTION

CHECK THE CORRECT INSTALLATION USING THE ALIGNMENT OF THE REFERENCE NOTCHES ON THE CRANKSHAFT AND ON THE TIMING SYSTEM GEAR

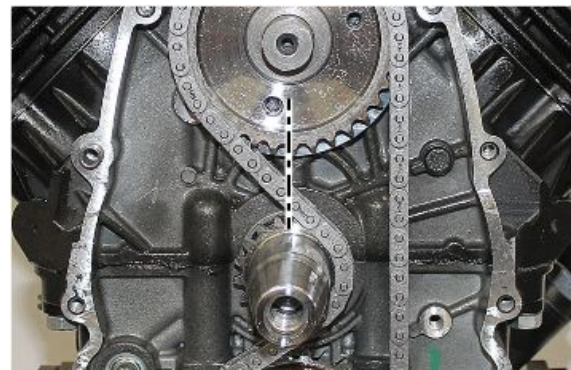

- Using a thin tool, refine the alignment of the oil pump pin with the milling on the gear of the pump itself.



- Fit the safety plug.



- Fit the knurled washer and after placing the nut, tighten it to the prescribed torque

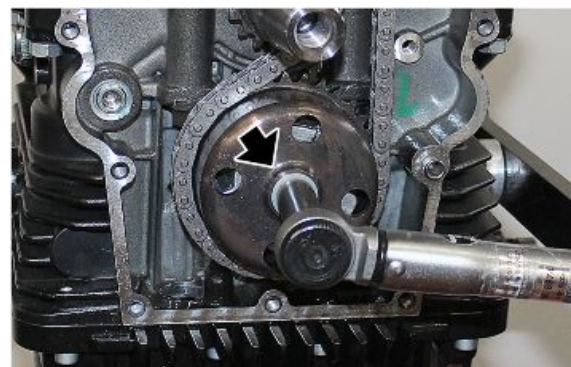

- Position the three fixing screws of the timing gear and tighten to the prescribed torque.

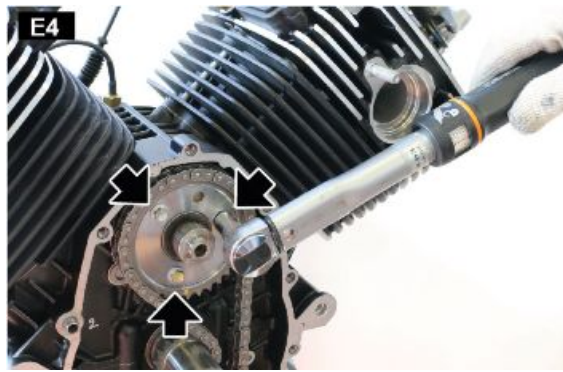

NOTE

ONLY FOR E4 VEHICLES

- Position the tone wheel and after inserting the fixing screw with washer, tighten to the prescribed torque.



NOTE

ONLY FOR E4 VEHICLES

- Fit the front chain guide on the timing system sprocket and then insert the three fixing screws and tighten them to the recommended torque.



NOTE

ONLY FOR E5 VEHICLES

- Fit the bulkhead on the camshaft, fit the fixing screw and tighten it to the recommended torque.



NOTE

ONLY FOR E5 VEHICLES

- Turn the crankshaft manually checking that there is no jamming. If jamming does occur, repeat the timing operation

Cylinder-piston assembly

Removing the cylinder

- Slide off the cylinder from the stud bolts.



- Remove the temperature sensor from the left cylinder.

NOTE

ONLY FOR E5 VEHICLES

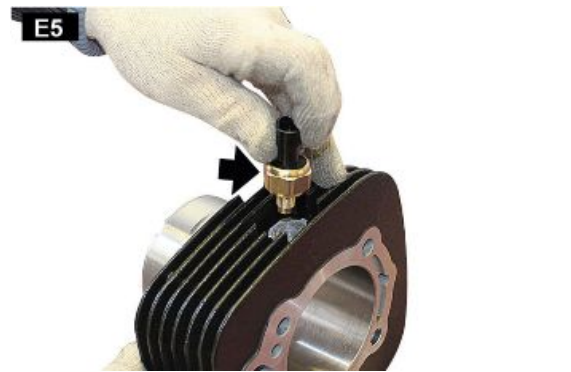

- Remove the gasket from the stud bolts



Disassembling the piston

- Remove one of the two retainer rings from the pin paying attention that it does not fall inside the engine

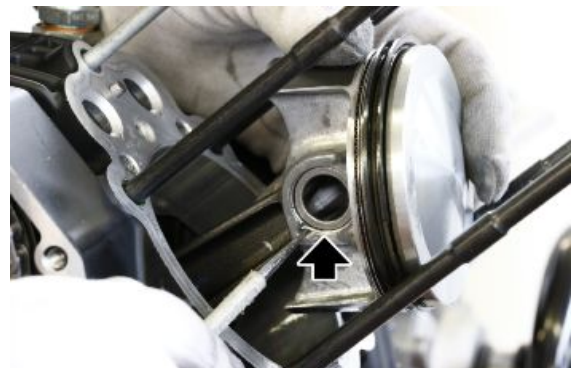

- Before removing the pin, check the mounting clearance between pin and piston. Replace it if the value is out of the limits
- Slide off the pin



Characteristic

Mounting clearance between piston and pin

0.01 mm (0.0004 in)

- Remove the piston

CAUTION

DURING SERVICING, CLEAN OFF ANY DEPOSITS FROM PISTON CROWN AND CIRCLIP GROOVES



Checking the cylinder

- After checking for scoring, check cylinder surface wear using a dial gauge graduated in hundredths of a millimetre.
- Measure the inner diameter of the cylinders at three different heights, turn the dial gauge (graduated in hundredths of a millimetre) 90° and repeat the measurements; set the dial gauge graduated in hundredths of a millimetre to zero using a ring gauge before measuring.

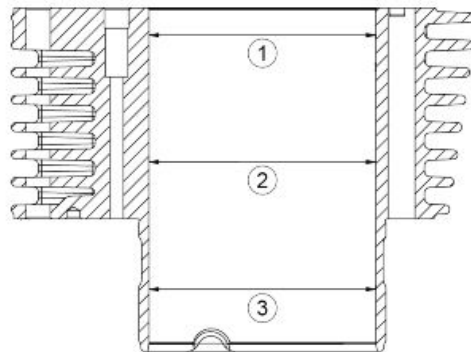

Key:

1. 1st measurement
2. 2nd measurement
3. 3rd measurement

CYLINDERS CONTROL

Type	Allowed diameter	Assembly clearance between piston and cylinder
G	84.000-84.007 mm (3.3071-3.3073 in)	0.040-0.054 mm (0.0016-0.0021 in)

Type	Allowed diameter	Assembly clearance between piston and cylinder
H	84.007-84.014 mm (3.3074-3.3076 in)	0.040-0.054 mm (0.0016-0.0021 in)
L	84.014-84.021 mm (3.3076-3.3079 in)	0.040-0.054 mm (0.0016-0.0021 in)
M	84.021-84.028 mm (3.3079-3.3082 in)	0.040-0.054 mm (0.0016-0.0021 in)

Checking the piston

- Measure the piston skirt diameter (1) with a micrometer from the piston lower border (2)=10 mm (0.39 in).
- Replace the cylinder, the piston and the piston ring all together if not complying with specifications.

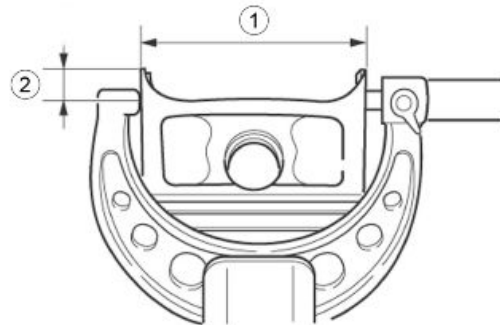

INSPECTING PISTONS

Type	Allowed diameter	Assembly clearance between piston and cylinder
G	83.953-83.960 mm (3.3052-3.3055 in)	0.040-0.054 mm (0.0016-0.0021 in)
H	83.960-83.967 mm (3.3055-3.3058 in)	0.040-0.054 mm (0.0016-0.0021 in)
L	83.967-83.974 mm (3.3058-3.3061 in)	0.040-0.054 mm (0.0016-0.0021 in)
M	83.974-83.981 mm (3.3061-3.3063 in)	0.040-0.054 mm (0.0016-0.0021 in)

Inspecting the wrist pin

PIN

- Clean off combustion residues from the piston crown and from the area above the top ring.
- Check for cracks on the piston and for compression on the piston sliding surface (seizing); Replace the piston if required.
- Measure the pin outside diameter (1) and if not complying with specifications; replace the pin.

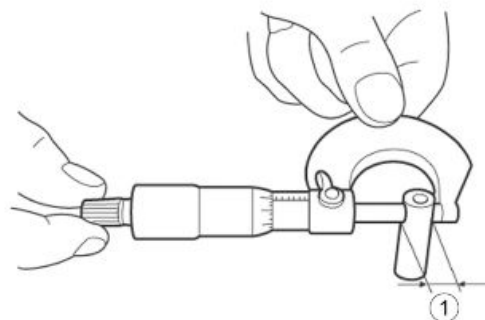

Characteristic

Pin external diameter (MINIMUM WEAR VALUE)

19.996 mm (0.7872 in)

Inspecting the piston rings

- Clean off any carbon deposits from the grooves in the piston rings and from the rings themselves.
- Measure the piston ring side clearance and replace the piston and the piston rings all together if not complying with specifications.

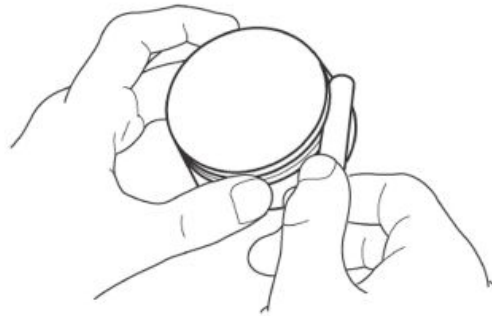

SEAL RING CLEARANCE (MAXIMUM WEAR VALUES)

Type	Maximum clearance between the rings and cables on the piston	Maximum opening of the rings mounted on the piston
Upper ring	0.07 mm (0.0028 in)	0.10-0.30 mm (0.0039-0.0118 in)
Intermediate ring	0.06 mm (0.0024 in)	0.35-0.55 mm (0.0138-0.0217 in)
Oil scraper ring	0.18 mm (0.0071 in)	0.20-0.70 mm (0.0079-0.0276 in)

- Fit the piston ring to the cylinder.
- Level the installed piston ring with the piston crown.
- Measure piston ring port and replace it if not complying with specifications.

CAUTION

IT IS NOT POSSIBLE TO MEASURE THE CLEARANCE OF THE END OF THE OIL SCRAPER RING: IF THERE IS EXCESSIVE PLAY, REPLACE THE THREE ELASTIC RINGS.

- Insert the piston rings paying attention to their mounting direction and end gap arrangement; the end gaps must be approximately 180 degrees from each other.

Fitting the piston

- Place the piston on the connecting rod notch

CAUTION

MOUNTING POSITION IS INDICATED BY AN ARROW POINTING IN THE DIRECTION OF TRAVEL



- Insert the pin



- Insert the retainer ring

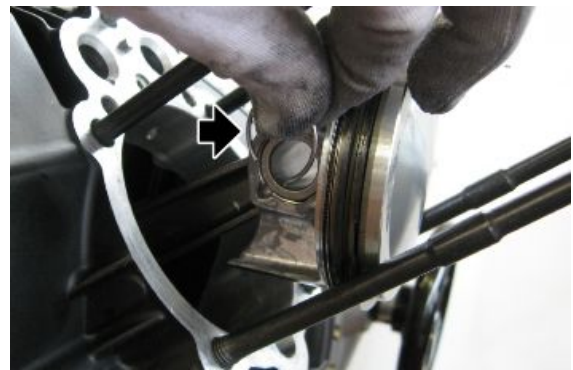

Installing the cylinder

- Check that the piston ring end gaps are approximately 120 degrees from each other.
- Fit a new gasket



- Fit the existing temperature sensor only on the left cylinder.

NOTE
ONLY FOR E5 VEHICLES



- Place the appropriate ring clamp on the piston
- Place the cylinder so that the piston correctly enters the seat and as soon as the segments zone is exceeded remove the ring clamp



Specific tooling

020128Y Piston fitting ring

- After fitting the cylinder it is necessary to check the piston projection for correct head gasket selection.
- Fit a dial gauge on the specific tool and set it to zero on a horizontal plane.



Specific tooling

020996Y Piston protrusion measurement tool

- Fit the tool together with the dial gauge on the cylinder and tighten the fixing nuts.
- Detect the deviation on the dial gauge



Specific tooling

020996Y Piston protrusion measurement tool

CAUTION

THE PISTON PROJECTION MUST BE DETECTED BY FITTING THE GASKET BETWEEN CRANK-CASE AND CYLINDER. BEFORE THE DETECTION TIGHTEN THE CYLINDER UNTIL THE GASKET IS COMPLETELY WOUND

HEAD GASKET SELECTION

Piston projection	Gasket thickness
0.40-0.58 mm (0.0157-0.0228 in)	0.6 +/- 0.05 mm (0.0236 +/- 0.0020 in)
0.20-0.40 mm (0.0079-0.0157 in)	0.8 +/- 0.05 mm (0.0315 +/- 0.0020 in)
0.02-0.20 mm (0.0008-0.0079 in)	1.0 +/- 0.05 mm (0.0394 +/- 0.0020 in)

- Place the cylinder.

Installing the cylinder head

- Insert the flame trap of the secondary air valve



- Insert the reed valve



- Fit the cover of the secondary air valve and tighten the screws to the prescribed torque



- Fit the engine oil pressure sensor, only in the left head and tighten it to the prescribed torque



NOTE
ONLY FOR E4 VEHICLES

- Place the gasket



- Place engine head into place



- Place the three rubber O-Rings, particularly apply grease to the O-Ring that will be inserted in the stud bolt in order to avoid damaging it



- Position the cam tower in its seat



- Following a cross order "A-C-B-D" screw the fixing nuts of the cam tower to the prescribed torque

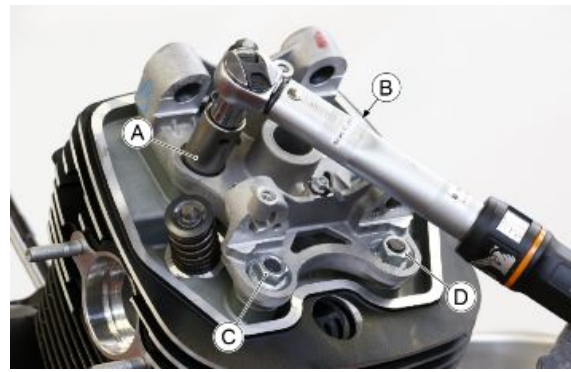

- Insert and tighten the compensation nut of the cam tower to the prescribed torque



- Position the washer with the relevant nut on the base of the cylinder and tighten to the prescribed torque.



- Insert the rocker rods

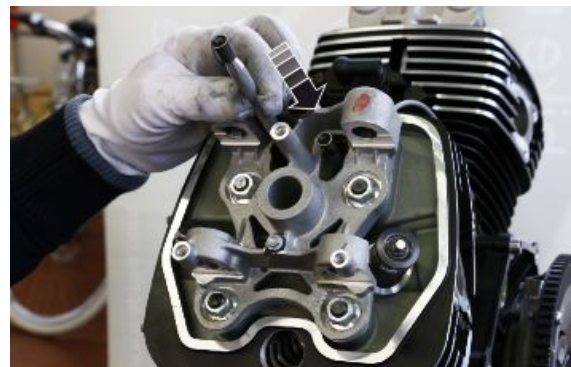

CAUTION



PRIOR TO POSITIONING THE ROCKERS, CHECK THAT THE CALIBRATED PAD ON THE INTAKE VALVE IS INSERTED.



- Place the rocker in its seat by inserting the Belleville spring at the same time

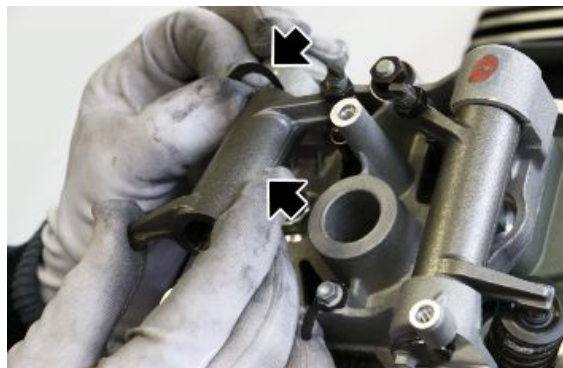

- Using the rocker shim centring pin, align the rocker and the Belleville spring with the pin seat for easy insertion

Specific tooling

020995Y Rocker arm centring pin

- Insert the rocker pin retainer fork on the pin and insert it in the seat

CAUTION

SLOWLY INSERT THE ROCKER PIN UNTIL THE FORK REACHES THE SUPPORT POINT ON THE CAM TOWER. THE INSERTION OF THE ROCKER PIN WITHOUT THE FORK REACHES A NON-CONTROLLED DEPTH

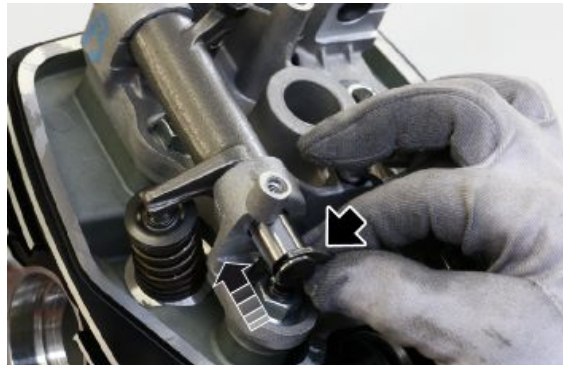

- Insert and tighten the fixing screw of the rocker pin lock fork to the prescribed torque

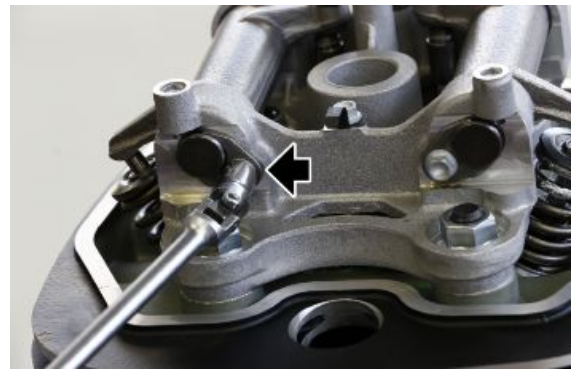

- Insert and tighten the spark plug to the prescribed torque



Installing the head cover

- Fit the gasket on the head cover



- Place the head cover together with the gaskets on the seats of the fixing screws



- Place the cover fixing screws and tighten them to the prescribed torque

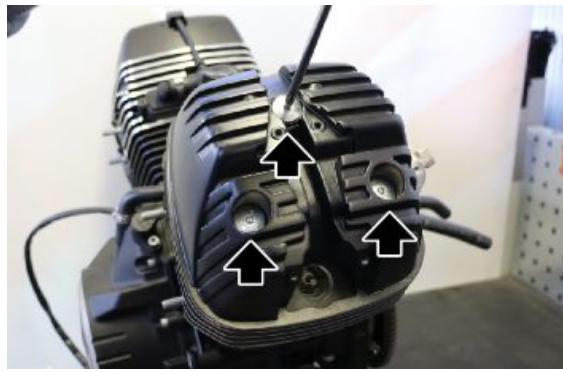

Crankcase - crankshaft

Splitting the crankcase halves

- Remove the bucket tappets, the oil sump, the filter and the overpressure valve.
- Unscrew and remove the six external nuts and their washers.

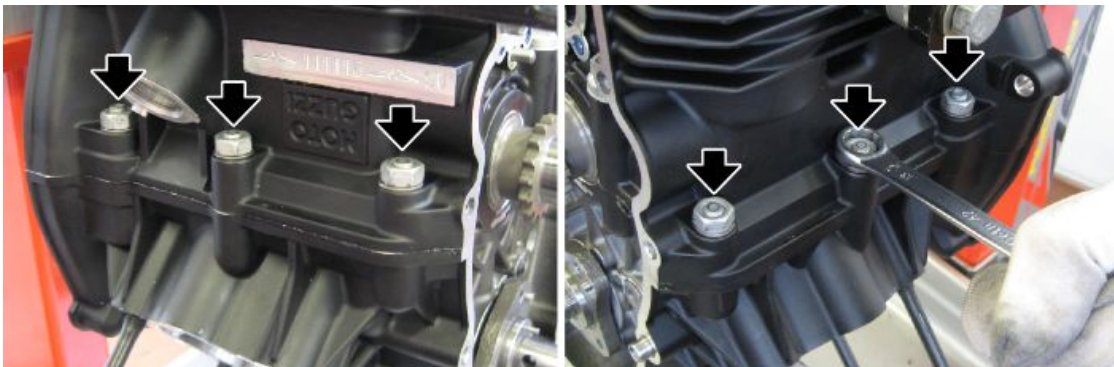

- Undo and remove the four long nuts from the inside of the crankcase.

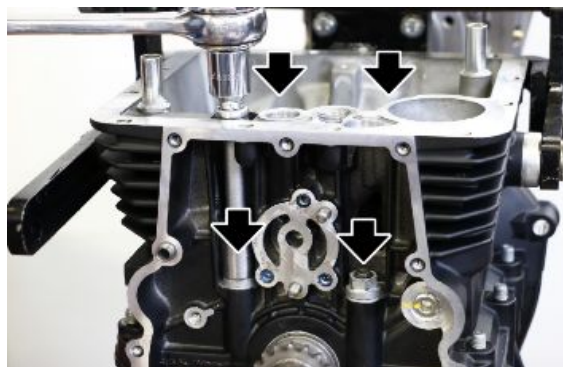

- Remove the upper crankcase being careful not to damage its mating face



- Remove the crankshaft together with connecting rods and small ends



Removing the crankshaft

- Remove the crankshaft connecting rods.
- Unscrew the oil plug and thoroughly clean the oilway and oil passages delivering oil to connecting rods and main journals.

See also

[Disassembling the connecting rod](#)

Disassembling the connecting rod

- Remove the screws and separate the connecting rod from the small end paying attention to the reference signs and the mounting direction.

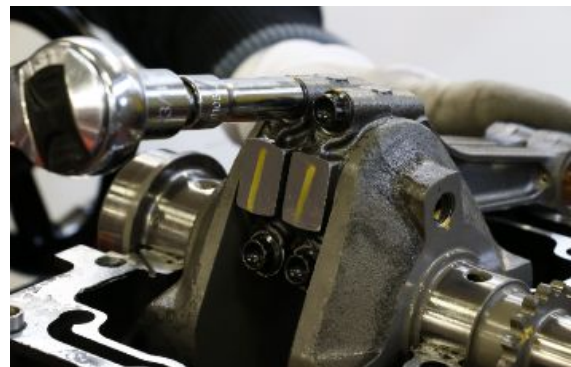

- Remove the small ends from the connecting rods.

CAUTION

REPEAT THE PROCEDURE FOR THE OTHER CONNECTING ROD

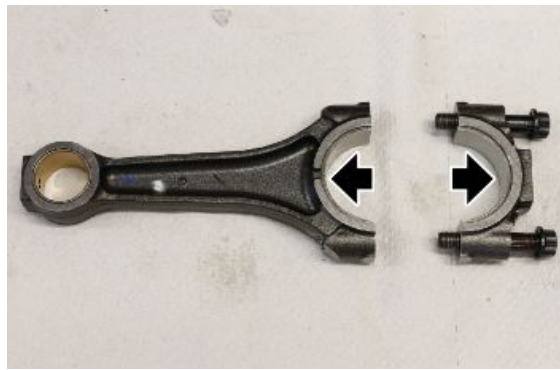

Inspecting the crankcase halves

- Check that the mating faces are not damaged, dented or scored. Remove the liquid gasket residues.
- Check that the threads of the stud bolts are not dented or stripped; if they are, replace the stud bolt or stud bolts.
- Blow all oil galleries of the two crankcase halves with compressed air.

Inspecting the crankshaft components

- Smear the thread of the cap with threadlocker and tighten the cap firmly.
- Blow with compressed air to clean the lubrication passage seats.

CAUTION

THE CRANKSHAFT IS NITRIDED AND CANNOT BE GROUND; IF WORN, TAPERED OR DEEPLY SCORED, THE CRANKSHAFT MUST BE REPLACED

CRANKSHAFT CHECK - LIMIT VALUES

Specification	Desc./Quantity
Main journal diameter on timing system side (WEAR LIMIT VALUE)	40.004 mm (1.5750 in)
Main bushing seat diameter on timing system side (MAXIMUM WEAR VALUE)	43.67 mm (1.7193 in)
Thickness for main bushing on timing system side (MAXIMUM WEAR VALUE)	1.805 mm (0.0711 in)
Main journal diameter on clutch side (MINIMUM WEAR VALUE)	43.007 mm (1.6932 in)
Main bushing seat diameter on clutch side (WEAR LIMIT VALUE)	47.142 mm (1.8560 in)
Total thickness for main bushing on clutch side (MINIMUM WEAR VALUE)	2.04 mm (0.0803 in)
Crankshaft thrust height (MAXIMUM WEAR VALUE)	24.81 mm (0.9768 in)
Crankcase thrust height (MINIMUM WEAR VALUE)	2.3 mm (0.0905 in)
Thickness of the thrust half-bearings on main bushing on clutch side (MINIMUM WEAR VALUE)	2.31 mm (0.0909 in)
Diameter of crank pin (MINIMUM WEAR VALUE)	39.995 mm (1.5746 in)

The maximum parallelism deviation of the two crankshaft axes (connecting rod pin and main journals on flywheel side and timing system side) should not exceed 0.02 mm (0.0009 in) at 40 mm (1.5748 in) distance.

Checking the connecting rod

- Check using a micrometer the measure of the connecting rod pin orthogonal axes an in the working area of the small ends, check the measure of the small ends seats on the timing system side and on the flywheel side.
- Assemble the connecting rod without small ends and tighten the connecting rod screws to the prescribed torque. Measure the outer diameter of small ends seats with a dial gauge graduated in hundredths of a millimetre and the thickness of both small ends with a round tip micrometer.
- Check the bushings pressed in the small end of the connecting rod for notches due to seizing or deep scoring; replace as required.

CONNECTING ROD CHECK

Specification	Desc./Quantity
Diameter connecting rod head seat (MAXIMUM WEAR VALUE)	43.67 mm (1.7193 in)
Thickness of connecting rod head small ends (MINIMUM WEAR VALUE)	1.807 mm (0.0711 in)
Diameter of the small end with pressed and bored bushing (MAXIMUM WEAR VALUE)	20.015 mm (0.7880 in)

Assembling the connecting rod

- Before assembly, take careful note of the reference markings and the correct direction of installation.
- There are two available models of connecting rods and the points where the laser marks or incisions are shown on the crankshaft may differ depending on the engine output:

A/blue - B/white (white or blue dot in the zone indicated by the letter **X** in the drawing) to be assembled correctly with the crankshaft, available in two models **A/blue - B/white** (laser mark or white or blue dot in the zone indicated by the letter **Y** in the drawing) for the crankpin, using the appropriate bushing.

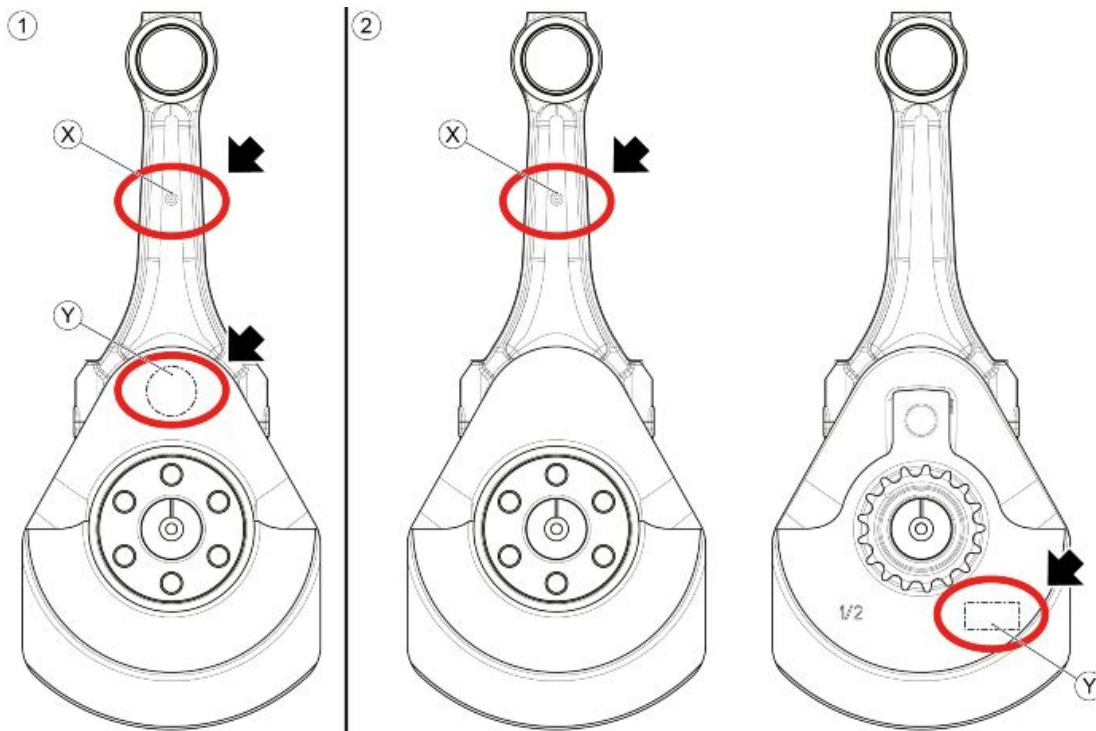

CONNECTING ROD HEAD BUSHING CLASSES

Selection class	Thickness
Red	1.807-1.811 mm (0.0711-0.0713 in)
Blue	1.811-1.815 mm (0.0713-0.0715 in)
Yellow	1.815-1.819 mm (0.0715-0.0716 in)

CONNECTING ROD/CRANKSHAFT CLASSES

Selection class	Connecting rod big end diameter	Crankshaft diameter
A (light blue)	43.657-43.664 mm (1.7188-1.7191 in)	39.995-40.003 mm (1.5746-1.5749 in)
B (white)	43.664-43.670 mm (1.7191-1.7193 in)	40.003-40.011 mm (1.5749-1.5752 in)

CONNECTING ROD/CRANKSHAFT ASSEMBLY CLASSES

Connecting rod selection class	Blue crankpin marking	White crankpin marking
A (light blue)	blue-blue	red-red
B (white)	yellow-yellow	blue-blue

- The radial play between the connecting rod and the crankshaft must be within the following range: 0.045-0.069 mm (0.0018-0.0027 in)
- The identifying colour point of the connecting rod selection must be oriented for both connecting rods towards the clutch side.

- Before assembly, take careful note of the coupling classes.
- Reassemble the connecting rods in the crankshaft seat on the crankpin by screwing the screws with the correct tightening sequence specified in the "characteristics" chapter, "tightening torque / engine" section in the "CRANKSHAFT" table".



Installing the crankshaft

If it is necessary to replace the crankshaft or the connecting rods, follow the reference table regarding the couplings between the "CONNECTING ROD weight class mark" (1) and the "CRANKSHAFT weight class mark" (2).

WARNING

MOUNT A PAIR OF CONNECTING RODS OF THE SAME CRANKSHAFT WEIGHT CLASS

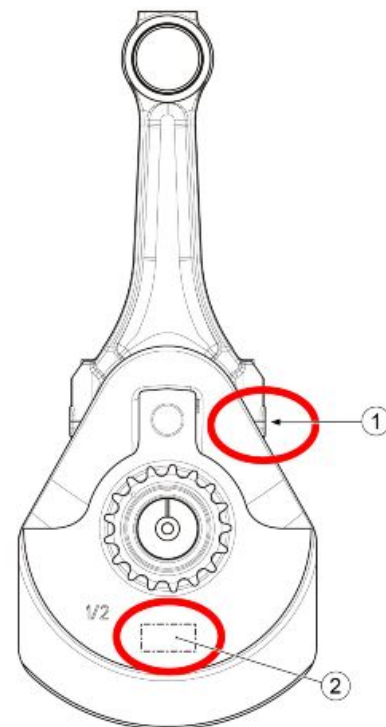

CONNECTING ROD/CRANKSHAFT WEIGHT CLASSES

CRANKSHAFT WEIGHT CLASS	CONNECTING ROD WEIGHT CLASS
E1	E1
E2	E2
E3	E3
E4	E4
E5	E5

Refitting the crankcase halves

- Insert the small ends timing system side and flywheel side on both crankcases paying attention to lubricate them

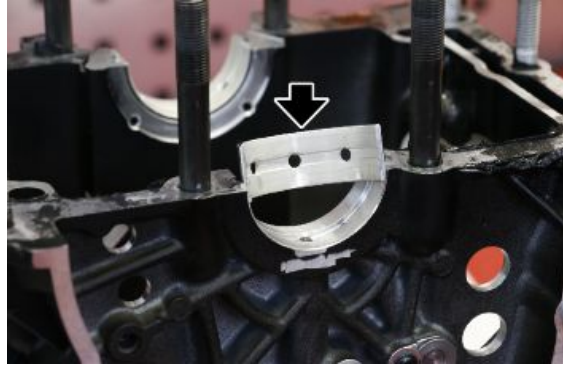

- With the help of grease, place the thrusts on the upper crankcase from the flywheel side, paying attention to lubricate them in the friction area

CAUTION

THE MOUNTING DIRECTION OF THE THRUSTS IS UNIQUE

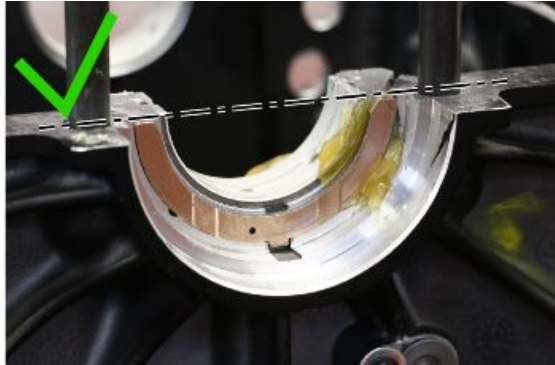

- Insert the seal ring (after lubricating it) on the crankshaft and the assembly onto the engine crankcase making sure that the connecting rods locate correctly into their seats.



- Smear the crankcases mating faces with the threebond

- Grasp the crankshaft assembly with the upper crankcase keeping the two components together, rotate them and lay them on the lower crankcase.



- Insert and screw the four long nuts and the six external nuts together with washers..
- Tighten all nuts to the prescribed torque proceeding with the cross order

Removing

- Remove the timing system complete with oil pump gear
- Using a hairdryer, heat the fixing base of the three oil pump screws.



- Remove the three fixing screws of the oil pump.

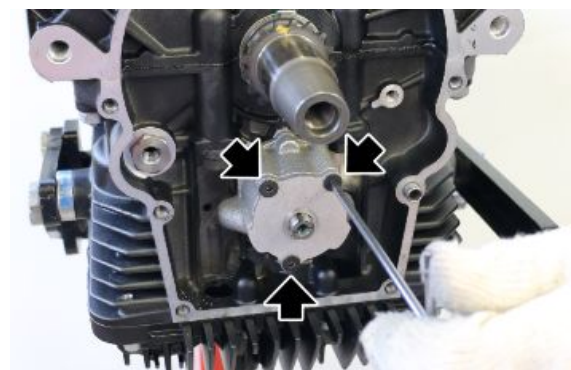

- Remove the complete pump from the crankcase.



- Remove the cover (1) from the pump (2).

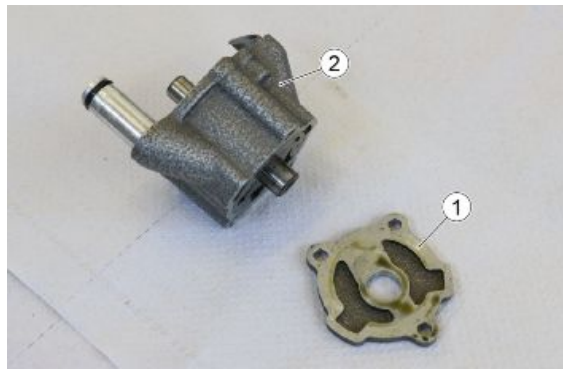

- Working on the oil pump gear side, remove the external rotor (3).



- Remove the internal rotor (4).



- Remove the safety pin (5) from the pump drive shaft.



- Working from the opposite side of the oil pump, extract the pump drive shaft (6) removing the internal rotor (7) and the external rotor (8).



Inspection

OIL PUMP BODY

Check that the faces and inner seats of the oil pump body are not scored, damaged or dented.

Pump body specifications:

OIL PUMP BODY

Description	Values
External rotors seat diameter (MAXIMUM WEAR VALUE)	40.675 mm (1.6014 in)
Diameter hole for pump drive shaft (MAXIMUM WEAR VALUE)	15.995 mm (0.6297 in)

EXTERNAL ROTORS

Check that the inner and outer surfaces and the flat faces are not scored, damaged or dented; if they are, replace both rotors of the side in question.

Data of the external rotors:

EXTERNAL ROTOR (ROTOR SIDE)

Description	Values
External diameter (WEAR LIMIT VALUE)	40.54 mm (1.5961 in)
Internal diameter (MAXIMUM WEAR VALUE)	24.23 mm (0.9539 in)
Thickness of seat (MAXIMUM WEAR VALUE)	12.07 mm (0.4752 in)

EXTERNAL ROTOR (CRANKCASE SIDE)

Description	Values
External diameter (WEAR LIMIT VALUE)	40.54 mm (1.5961 in)
Internal diameter (MAXIMUM WEAR VALUE)	24.23 mm (0.9539 in)
Thickness of seat (MAXIMUM WEAR VALUE)	14.07 mm (0.5539 in)

INTERNAL ROTOR

Check that the inner and outer surfaces and the flat faces are not scored, damaged or dented; if they are, replace both rotors of the side in question.

Data of the internal rotors:

INTERNAL ROTOR (ROTOR SIDE)

Description	Values
External diameter (MAXIMUM WEAR VALUE)	29.749 mm (0.1712 in)
Internal diameter (MAXIMUM WEAR VALUE)	12.018 mm (0.4731 in)
Thickness (MINIMUM WEAR VALUE)	11.97 mm (0.4713 in)

INTERNAL ROTOR (CRANKCASE SIDE)

Description	Values
External diameter (MAXIMUM WEAR VALUE)	29.749 mm (0.1712 in)
Internal diameter (MAXIMUM WEAR VALUE)	12.018 mm (0.4731 in)
Thickness (MINIMUM WEAR VALUE)	13.97 mm (0.5500 in)

OIL PUMP DRIVE SHAFT

Check shaft and thread for damage; check the keyway for burrs and make sure the head the runs in the rotor is not damaged; replace the shaft if needed.

Shaft specifications:

OIL PUMP DRIVE SHAFT

Description	Values
Diameter for pump body seat (MINIMUM WEAR VALUE)	11.989 mm (0.4720 in)
Diameter seat for roller bearings (MINIMUM WEAR VALUE)	9.991 mm (0.3933 in)

Installing

- Working from the rear side of the oil pump, insert the pump drive shaft (1) the internal rotor (2) and the external rotor (3).



- Working from the front of the oil pump, insert the internal rotor retaining pin (4).



- Insert the internal rotor (5) paying attention that the pin enters the machining seat.



- Insert the external rotor (6) paying attention to the punch mark that must be facing outwards.



- After inserting the cover, position the complete oil pump in place.



- Insert the three oil pump retaining screws and tighten them to the pre-defined tightening torque.

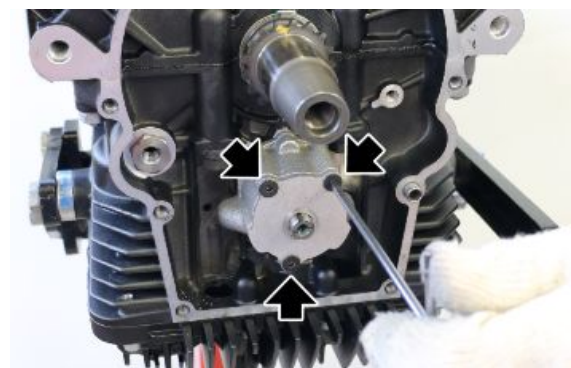

Oil sump

Removing the oil sump

- Remove the engine oil filter fixing screw



- Remove the engine oil filter



- -Remove the 14 fastening screws of the oil sump



- Remove the oil sump



- Remove the gasket



- Remove the rose pipe



- Remove the cap and the relative copper gasket



- Remove the spring



- Remove the overpressure valve



Refitting the oil sump

- Install the overpressure valve in the engine crankcase



- Insert the spring and afterwards the cap provided with a new copper gasket, tighten it to the prescribed torque



- Insert the rose pipe



- Place the gasket and insert the oil sump cover



- Insert and tighten the 14 fastening screws of the oil sump to the prescribed torque

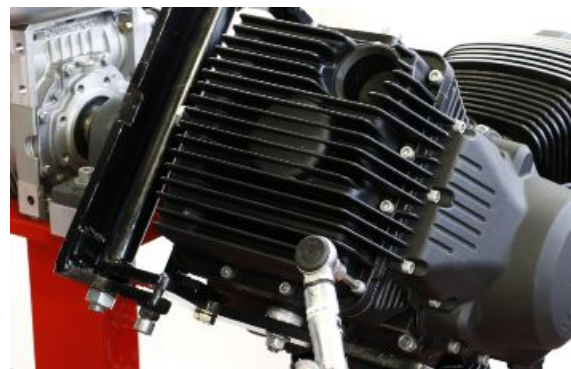

- Insert the engine oil filter together with the cover



- Insert and tighten the locking screw of the engine oil filter to the prescribed torque



C

Chain: 73

Chain tensioner: 73

Clutch: 39, 41, 53, 54, 56, 57

Crankcase: 92, 94, 98

Crankshaft: 92–94, 97

Cylinder: 63, 67, 81, 82, 85, 87

D

Desmodromic drum: 41

F

Forks: 41

H

Head cover: 62, 91

M

Magneto flywheel:

O

Oil sump: 103, 104, 106

P

Pistons:

Primary shaft: 29

S

Secondary air system:

Secondary shaft: 33

Start-up:

Starter motor: 53

T

Throttle body: